

CoviDoor. IoT Based Temperature Sensing Door Handle

^{1,1} Sohaib Usmani, ¹ Syed Taha Bukhari, ¹ Noman Farrukh, ^{1,2} Imran, ¹ Laiq Muhammad Khan

¹ *College Of Computer Sciences & Information Systems (CCSIS), Institute of Business Management (IoBM), Karachi, Pakistan*

² *Malaysian Institute of Information Technology, Universiti Kuala Lumpur (UniKL MIIT), Kuala Lumpur, Malaysia*

Abstract- The continuous development of IoT innovation assumes a crucial part in building up the wellbeing region by making it dramatically more accessible and moderate by making it easier to utilize applications for simulated and removed patient connections. With the skill of IoT technology, it is conceivable to solve the complications that truly dysfunctional patients encounter while really routinely counseling a professional. An IoT-based model which is remote health system for patients has been prompted by this work. Three wellness sensors are included in this model: heart beat sensor, internal heat level sensor, and galvanic skin reaction sensor. With Arduino, Uno and Raspberry Pi joined together, all of these sensors were consolidated into a solitary system. The information obtained from the sensors is transferred via the Raspberry Pi to a distributed storage. The distributed storage continuously refreshes the information base continuously. Using Android Studio, an Android application was developed that could get to the data base and display a visual representation of the limits of wellbeing. The need to attend clinics for critical medical conditions can be beaten by IoT coordinated with the well-being wearable. In addition, this fundamentally decreases the treatment costs for patients. In addition, by noticing the patient's well-being information over the long haul via an application, the specialists will support critical medications. In order to understand the operation of the sensors used, point by point analysis of the signs was obtained concerning varieties of physical and natural exercises.

As of late among clinical experts, designs just like IT experts, the far off well-being observing system has been an interesting topic. In any event, in several nations, the use of a distant well-being monitoring approach where specialists can screen the vital signs of patients through the web is new for all intents and purposes. The distant well-being monitoring system is advantageous for patients and community in 2017 where the use of such a framework would save hospital fees, hold up time and reduce clinic deals. The aim of this undertaking is to plan and develop an internal heat level estimation system that can be continuously seen by the specialist across the web as history data with an alert/sign in the event of irregularities. Remote sensors for pulse and internal heat level have been established in the proposed well-being control system, but this paper only relies on the remote observing framework for internal heat level. Using Arduino UNO communication, the various sensors will give the measurements to a different microcontroller. Remote neighbourhood (WLAN) has been used to submit the genuine information to the wellness checking information base. For this reason, Arduino has been utilized with the IEEE 802.11 standard. Test results from a deliberate set show the ongoing temperature being effectively observed locally, remotely and the evaluations are equivalent to business thermometer.

Keywords: control system, IoT, temperature, sensor.

I. INTRODUCTION

^{1,2}(std_20171-22367, std_20171-22533, std_20171-2262, imran.ali, liaq.muhammad)@iobm.edu.pk

²imran.ali@s.unikl.edu.my

Advances in technology have made miniature versions of modern things usable in this generation [1]. Through this development, the framework of health monitoring is in it [2]-[4] for individual medical care, wellness and clinical awareness, the utilization of far off health observing systems has acquired enormous popularity in last few years. This equipment, patients or incapacitated people can be checked by distant clinical personnel and authorized faculty. The cloud-based health observing system can recognize crisis clinical circumstances and give biofeedback through early notice. This system empowers older patients to stay in contact with their families, and their families can generally comprehend their situation. This is a distant health checking gadget, it can get all the information and move the information to the cloud, which would then be able to be gotten to by its clinical supplier and authorized faculty[5]. These gadgets may build the shot at enduring unintentional sicknesses [6].

The accessibility of without and wireless sensor networks makes remote health monitoring possible. Body temperature and heart rate measurement. The device is an example of a wireless sensor utilized in medicinal equipment dobrescu and others. (2008) cited that the evolution of the different Internet facilities and without using wired sensors has opened up chances for healthcare [7]. Wireless sensor networks have many advantages when statistics gathering and observing services are feasible [8]. In health observing, this technology permits patients to observe their significant signs at home and wirelessly transmit the results to hospital professionals. In fact, before the patient needs emergency care, doctors can improve their ability to solve problems [9].

II. LITERATURE REVIEW

A. *The Architecture of the CoviDoor*

CoviDoor is a framework driven by Arduino, composed of integrated sensors, processors and communication devices. All these functions gather together to exchange and execute information from the climate. This standard of the Internet of Things [10] allows its administrators to remotely access gadgets through the remote cloud innovation to interconnect gadgets. These gadgets should have the advantage of the network so that they can talk to other smart gadgets without external mediation [11]. There are basically four design stages. Different stage perform various operations. Phase 1 includes how many gadgets are connected to obtain raw data that can be used for further analysis. Usually, it contains various sensors, which can be using wire or without wire. In the second stage, the group of relevant figures is accomplished so that it can be interrelated to the Internet. The

A to D conversion is started at this step. In the third step, the data pre-processing is performed through the IT system, and then enters the last step (stage 4), in which the filtered, analyzed, and processed the data which is kept in the cloud-based system[12] in the predictable back-end system [13].

B. Standard of Photoplethysmography

The photoplethysmography procedure is the most cutting-edge strategies for estimating internal heat levels. The rule it uses is to transmit infrared light and receive infrared light after natural tissue reflects and retains the light. The light passing through the natural tissues may be consumed by various parts of the interior because certain iconic changes in the obtained light, which can be additionally checked to shield the pulse.

In order to execute the project without any system errors, make sure to calibrate each component separately beforehand. The different settings were merged together which achieve the main goal of the project “see Fig.1”. The following sections describe how to implement the entire project in turn, and then merge them together to achieve the final output [14].

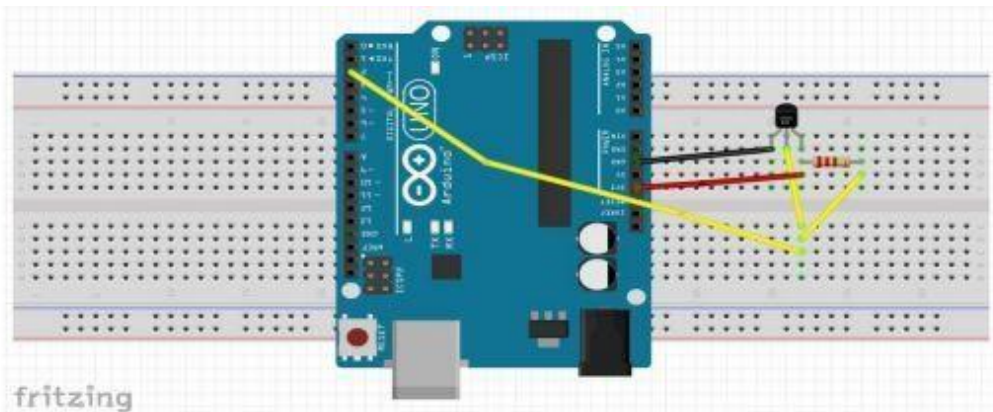

Figure 1. The body temperature measurement

The body temperature measurement implementation:

The body temperature at its best, to ensure that the body's enzymes work under the best conditions required. It can prevent the human body temperature from increasing or dropping to unhealthy levels, else, if the body temperature rises, it is not consistent, it will be fatal because the enzymes will not function properly “see Fig.2,”.

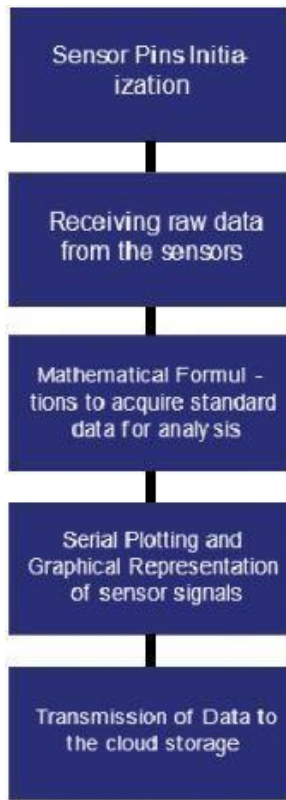

Figure 2. Circuit implementation of body temperature measurement

III. METHODOLOGY

A. FUNCTIONS OF LM35 SENSOR

LM35 is a coordinated the temperature sensor. The yield voltage LM35 linear relative Celsius temperature, at standard temperatures, it can give \pm one forth $^{\circ}\text{C}$ normal precision of room temperature without need extra alignment. The test utilized a LM35DZ-92 sort temperature sensor with plastic packaging. The pin limits as shown in figure 1, fundamental working limits are:

- Voltage: DC 4 ~ 30V
- Current which is less than 133 μA
- O/P voltage is + 6V to 1.0V
- O/P impedance is 1mA load 0.1ohm

- Accuracy is 0.5 °C (in + 25 °C)
- Leak current is > 60 uA
- Nonlinear value: $\pm 1/4$ °C.

B. Temperature Device

In this development, wired human temperature and heart rate sensors. This article just focuses on temperature sensors. In any case, both LM35 and TMP36 both are the appropriate for the estimation of the human body's internal heat level because of its higher precision and a wider range of partners, so LM35 has been selected. LM35 is a coordinated circuit temperature gadget. The yield voltage additionally has directly corresponding to Celsius temperature. The highlights of LM35 low yield impedance, adjusted straightforwardly in °Celsius (Centigrade) and direct + 10.0 mV/°C scale factor. It is additionally reasonable for far off applications. Table I shows the temperature reading with different method, Fig. 3 shows actual LM35 and its association.

TABLE I
COMPARISONS OF THE TEMPERATURE READING (AVERAGE) WITH DIFFERENT METHOD.

Method	Temperature Reading (°C)	Percentage of Error (%)
Hand - digital thermometer	33.4	4.84
Hand – Temperature sensor	35.23	0.37

The voltage-temperature conversion basic formula for LM35 is given by, Temp in °C = [V Out in mV] / 10

C. Data Processing Unit

Arduino is utilized to make association between measuring gadgets to constant checking database by means of wired associations.

LM35 was used for the main temperature monitoring device. Since, Test outcome demonstrations that the planned temperature sensor gives in a way that is improved than commercial computerized thermometer when the estimation is taken in the hand. Accordingly, hand temperature estimations

were considered in the investigations. Besides for a compact gadget, temperature is more helpful to be estimated close by.



Figure. 3 The LM35 (Texas Instruments)

Arduino IDE software was used to program the microcontroller (Arduino Uno) so that the signal from the temperature sensor can be represented in digital form.

The LM35 sensor is one of the qualities of this sensor is that it is sensitive. This sensor can be executed in different fields e.g. screen the temperature in concrete. The measure of warmth needs to oversee appropriately, one strategy to screen the temperature of the concrete during the solidifying cycle, the sensor utilized is LM35.

In this study, Manuel Ramos [15] used LM35 as one of the sensors utilized to check the excellence of concrete under heating conditions. Therefore, it can be seen from the system block diagram that the sensor used is a 2-32 LM35 sensor connected to the data gaining module. According to the analysis results, the different sensors used, so that the quality of the concrete can be understood.

The LM35 sensor is utilized to transform temperature into electricity. The input pin of the LM35 sensor is different from the DHT11 temperature and humidity sensor. The difference lies in the location of the input data. The theory of LM35 uses analog input data from the Arduino board, while DHT11 uses digital input data from the Arduino board, following the LM35 sensor in Fig. 4 [16].

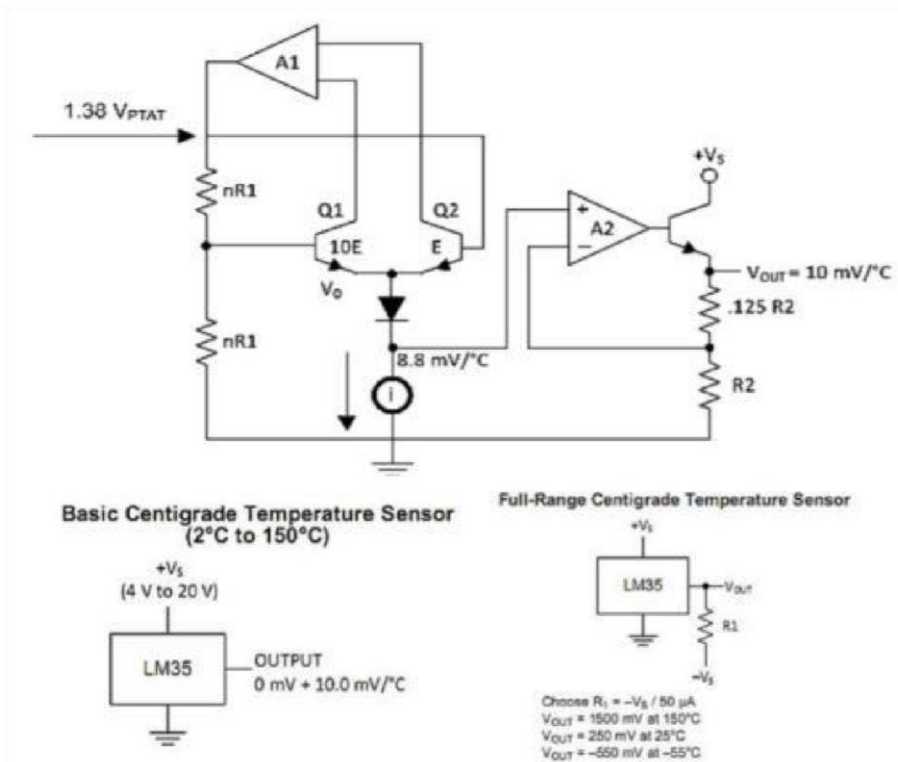

Figure 4. Schematic of LM35 sensor

IV. RESULT ANALYSIS

Primarily, the device was executed separately aimed at the observation of internal heat levels, but it can be used for heartbeat checks and galvanic skin reactions. For each internal heat level boundary, investigate the results obtained by changing behavior or ecological elements to improve the understanding of how the sensor works according to several changes. The above is a survey of signs procured and how they have been converged to move the information to the processor.

V. CONCLUSION

For the progress and progress of patients, the field of health has been constantly developing. Researchers and experts have been using the latest developments to make continuous improvements to bring such improvements into the field of well-being. In the long run, related innovations have always been the mainstream concern. This article leans toward the current demand for well-being-

based innovations that can be further developed into capabilities and solve the problems of unreliable people in society. A larger number of sensors is combined, such as respiratory rate sensors, pulse sensors and blood glucose sensors. These sensors can deliver a complete set of health observation frameworks for the purchasers of the project, because it can filter out the entire critical boundary of the human body. This can not only reduce the pressure of outpatient visits, reduce hospital costs and draw different conclusions, but also foresee the early occurrence of major diseases that may life security. This will be a main progress in this work and will have enormous and controllable influence on the well-being field.

The goal of this project has been effectively accomplished. Internal heat level estimation for far off wellbeing checking has been planned and created. The framework gives solid estimations and very easy to understand. The gadget and the framework can be worked on as far as estimating and joining between greater estimation gadgets, for instance, electrocardiography (ECG).

REFERENCES

- [1] Kamal, M. A., Alam, M. M., Khawar, H., & Mazliham, M. S. (2019, December). Play and Learn Case Study on Learning Abilities Through Effective Computing in Games. In 2019 13th International Conference on Mathematics, Actuarial Science, Computer Science and Statistics (MACS) (pp. 1-6). IEEE.
- [2] Jawbone Inc., "Jawbone fitness trackers," [Online]. Available: <https://jawbone.com/up/trackers> Accessed on 12th March 2018.
- [3] Fitbit Inc., "flex: Wireless activity + sleep wristband," [Online]. Available: <https://www.fitbit.com/flex> Accessed on 12th March 2018.
- [4] Apple Inc., "Apple watch," [Online]. Available: <https://www.apple.com/watch/>, Accessed on 12th March 2018.
- [5] Kamal, M. A., & Kamal, M. K. (2018). Context-Aware Perspective Analysis working of RFID Anti-Collision Protocols. *Journal of Independent Studies and Research Computing*, 16(2), 19-32.
- [6] Technology Intelligence, "8 Best Fitness Tracker" accessed April 2018. [Online]. Available: <https://www.telegraph.co.uk/technology/0/best-fitness-trackers-2017/> Accessed on 20th April 2018.
- [7] R. Dobrescu, D. Popescu, M. Dobrescu & M. Nicolae, "Intergration of WSN-based platform in a homecare monitoring system", *Latest Trends on Communications and Information Technology*, 2008, pp. 165-170.
- [8] E. Jovanov, A. Milenkovic, C. Otto & P. A. Groen, "A wireless body area network of intelligent motion sensors for computer assisted physical rehabilitation", *J. Neuroeng. Rehabil.*, 2005, vol 2.
- [9] A. H. Kiourmars & L. Tang, "Wireless Network for Haealth Monitoring Heart Rate and Temperature Sensor", *Fifth International Conference on Sensing Technology*, 2011, pp. 362-368
- [10] Raza, H. W., Kamal, M. A., Alam, M., & Su'ud, M. M. (2021). A Review of Middleware Platforms in Internet of Things: A Non-Functional Requirements Approach. *Journal of Independent Studies and Research Computing*, 18(1).

- [11] Kamal, M. A., Alam, M. M., & Mazliham, M. S. Routers Perspective Simulation-Based Analysis of EIGRP and OSPF Routing Protocol for an Organizational Model.
- [12] Kamal, M. A., Raza, H. W., Alam, M. M., & Su`ud, M. M. (2020). Highlight the features of AWS, GCP and Microsoft Azure that have an impact when choosing a cloud service provider. *International Journal of Recent Technology and Engineering (IJRTE)*.
- [13] "The 4 stages of an IoT architecture" [Online]. Available: <https://techbeacon.com/4-stages-iot-architecture> accessed on 31 July 2018.
- [14] Kamal, M. A. (2021). Arduino Controlled Spy Robo Car using Wireless Camera With live Streaming. arXiv preprint arXiv:2108.03402.
- [15] Zhiyu Li, Qiangui Xiao. "Design of temperature control system based on LM35 temperature sensor," *Micro computer information*, 20(9), 2004, pp. 51-52.
- [16] Manuel Ramos "Characterization of LM35 Sensor for Temperature Sensing of Concrete" *Proceedings of the International MultiConference Of Engineers and Computer Scientists 2017* , March 15 – 17, Hong kong Vol II, IMECS 2017
- [17] <http://www.ti.com/lit/ds/symlink/lm35.pdf> access date : 12 November 2018.