

ISSN 2224-2333 (Online)  
ISSN 2222-9930 (Print)

# PAKISTAN JOURNAL OF ENGINEERING TECHNOLOGY AND SCIENCE

VOLUME 9 NUMBER 2

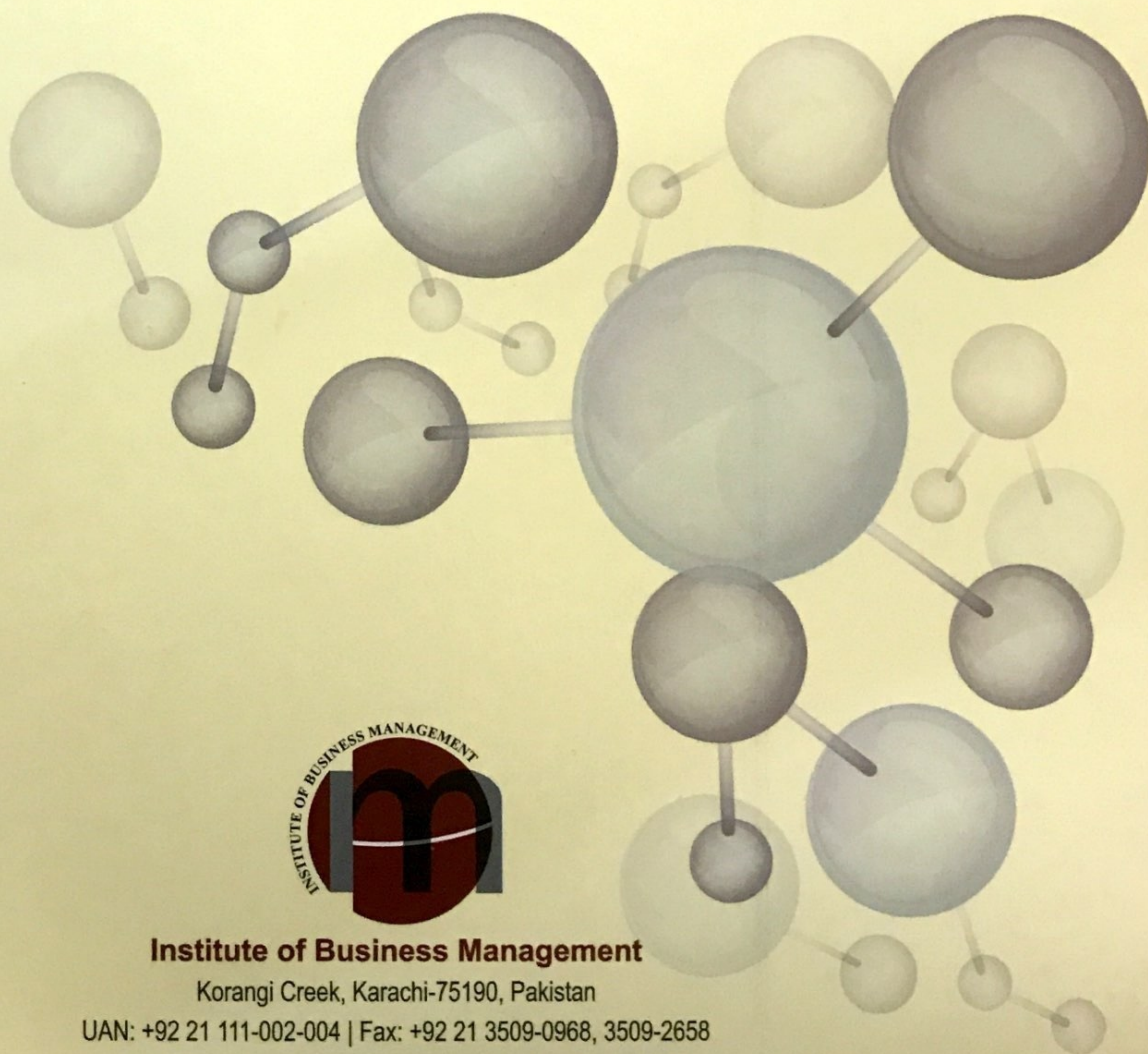

**Institute of Business Management**

Korangi Creek, Karachi-75190, Pakistan

UAN: +92 21 111-002-004 | Fax: +92 21 3509-0968, 3509-2658

URL: <http://journals.iobmresearch.com/index.php/PJETS>

URL: <http://www.iobm.edu.pk> | e-mail: [pjets@iobm.edu.pk](mailto:pjets@iobm.edu.pk)

## **Editors' Note**

I am very much pleased to introduce new editorial team who took the charge from Vol.9, issue No. 1, March 2021 and onwards. PJETS has changes its review process, by introducing single non-blind internal review and double-blind external reviews. This means that initially after successful internal review, papers sent for double-blind external reviews having both the reviewers and author(s) identities kept confidential. The scope of PJETS is publishing and promoting innovative ideas and original research in the field of Science, Technology, Engineering and Statistical Science since 2011, twice a year. This journal aims at publishing authentic research papers with less than 19% of plagiarism to create a culture of innovation and scientific development. The focus of the journal is limited to “Computer Science”, “Engineering”, relative “Emerging Technologies”, along with “Mathematics” and “Statistics”

The mission of PJETS is to provide a platform to the researchers, faculty and students to spread their findings. The main goal is to link authors from different professions, for example academia and non-academia in particular and encourage them to share their research. We fortunately succeeded in developing a new editorial review board comprising of reputed scholars and researchers national and international level, from academia and non-academia.

I hope the new editorial team will be great boon to give new energy to the journal and will impart their knowledge and experience to improve the quality of publications.

Vol 9 No. 2 Published in December 2021

**Dr. Zahid Ahmed**  
**Editor**

**Chief Editor**

Dr. Tariq Rahim Soomro  
Professor, Dean and Acting Rector  
College of Computer Science & Information Systems

**Editor**

Dr. Zahid Ahmed  
Assistant Professor  
College of Computer Science & Information Systems

**Associate Editors**

Dr. Zeshan Shahid  
Associate Professor  
College of Engineering & Sciences

**Editorial Officer**

Muhammad Humayoun

**Editorial Advisory Board (Internal)**

Dr. Syed Irfan Hyder  
Dr. S.M. Aqil Burney  
Dr. Ejaz Ahmed  
Dr. Mohammad Irshad Khan  
Dr. Shahid Amjad  
Dr. Fatima Riaz  
Dr. Insia Hussain  
Dr. Ehsan Rehman  
Dr. Imran Majid  
Dr. Khurram Iqbal  
Dr. Zeeshan Shahid  
Dr. Seema Ansari  
Dr. Abdul Hanan Sheikh

**Editorial Advisory Board (International)**

Prof. Dr. Mazliham Mohd Su'ud, President, Universiti Kuala Lumpur, **Malaysia**  
Prof. Dr. Ghassan Al-Qaimari, President, Emirates College of Technology, Abu Dhabi, **UAE**  
Prof. Dr. Patrice Boursier, Universite de La Rochelle, La Rochelle, **France**  
Prof. Dr. Mudassir Uddin, Professor, University of Karachi, **Pakistan**  
Dr. Nadeem Doudpota, Associate Professor, Al-Baha University, **KSA**  
Dr. Haithem Abdelrazaq Almfleh, Associate Professor, Yarmouk University, Yarmouk, **Jordan**  
Dr. Saiful Islam Ansari, Assistant Professor, University of Tabuk, **Saudi Arabia**

## Contents

<b>CoviDoor. IoT Based Temperature Sensing Door Handle</b> Sohaib Usmani, Syed Taha Bukhari, Noman Farrukh, Imran and Laiq Muhammad Khan	73-81
<b>Improvement of cardiovascular Diseases by Pine (Pinus) Nut Oil and its Alternatives</b> Zartaj MALIK	82-95
<b>INVESTIGATION INTO THE PERFORMANCES OF SUPERVISED LEARNING ALGORITHMS IN DIFFERENT PHISHING DATASETS</b> Oyelakin A. M., Olatinwo I. S., Rilwan D. M., Azeez R. D., and Obiwusi Y. K	96-104
<b>AN OVERVIEW ON APPLICATION OF SIX SIGMA METHODOLOGY IN PLASTICS INJECTION MOLDING INDUSTRY</b> Muhammad Iqbal Asif, 2Tariq Khan, 2M. N Babar	105-118
<b>Madadgar(Anti theft-SOS) Android App</b> Amna Waqar, Syeda Khadijia Hamid, and Mohammad Ayoub Kamal	119-135
<b>DIVERSITY AND UTILIZATION OF DYNAMIC PROGRAMMING (DP): A BRIEF OVERVIEW</b> Maryam Younus and Iqra Rehman	136-148

# CoviDoor. IoT Based Temperature Sensing Door Handle

<sup>1,1</sup> Sohaib Usmani, <sup>1</sup> Syed Taha Bukhari, <sup>1</sup> Noman Farrukh, <sup>1,2</sup> Imran, <sup>1</sup> Laiq Muhammad Khan

<sup>1</sup> *College Of Computer Sciences & Information Systems (CCSIS), Institute of Business Management (IoBM), Karachi, Pakistan*

<sup>2</sup> *Malaysian Institute of Information Technology, Universiti Kuala Lumpur (UniKL MIIT), Kuala Lumpur, Malaysia*

**Abstract-** The continuous development of IoT innovation assumes a crucial part in building up the wellbeing region by making it dramatically more accessible and moderate by making it easier to utilize applications for simulated and removed patient connections. With the skill of IoT technology, it is conceivable to solve the complications that truly dysfunctional patients encounter while really routinely counseling a professional. An IoT-based model which is remote health system for patients has been prompted by this work. Three wellness sensors are included in this model: heart beat sensor, internal heat level sensor, and galvanic skin reaction sensor. With Arduino, Uno and Raspberry Pi joined together, all of these sensors were consolidated into a solitary system. The information obtained from the sensors is transferred via the Raspberry Pi to a distributed storage. The distributed storage continuously refreshes the information base continuously. Using Android Studio, an Android application was developed that could get to the data base and display a visual representation of the limits of wellbeing. The need to attend clinics for critical medical conditions can be beaten by IoT coordinated with the well-being wearable. In addition, this fundamentally decreases the treatment costs for patients. In addition, by noticing the patient's well-being information over the long haul via an application, the specialists will support critical medications. In order to understand the operation of the sensors used, point by point analysis of the signs was obtained concerning varieties of physical and natural exercises.

As of late among clinical experts, designs just like IT experts, the far off well-being observing system has been an interesting topic. In any event, in several nations, the use of a distant well-being monitoring approach where specialists can screen the vital signs of patients through the web is new for all intents and purposes. The distant well-being monitoring system is advantageous for patients and community in 2017 where the use of such a framework would save hospital fees, hold up time and reduce clinic deals. The aim of this undertaking is to plan and develop an internal heat level estimation system that can be continuously seen by the specialist across the web as history data with an alert/sign in the event of irregularities. Remote sensors for pulse and internal heat level have been established in the proposed well-being control system, but this paper only relies on the remote observing framework for internal heat level. Using Arduino UNO communication, the various sensors will give the measurements to a different microcontroller. Remote neighbourhood (WLAN) has been used to submit the genuine information to the wellness checking information base. For this reason, Arduino has been utilized with the IEEE 802.11 standard. Test results from a deliberate set show the ongoing temperature being effectively observed locally, remotely and the evaluations are equivalent to business thermometer.

**Keywords:** control system, IoT, temperature, sensor.

## I. INTRODUCTION

---

<sup>1,2</sup>(std\_20171-22367, std\_20171-22533, std\_20171-2262, imran.ali, liaq.muhammad)@iobm.edu.pk

<sup>2</sup>[imran.ali@s.unikl.edu.my](mailto:imran.ali@s.unikl.edu.my)

Advances in technology have made miniature versions of modern things usable in this generation [1]. Through this development, the framework of health monitoring is in it [2]-[4] for individual medical care, wellness and clinical awareness, the utilization of far off health observing systems has acquired enormous popularity in last few years. This equipment, patients or incapacitated people can be checked by distant clinical personnel and authorized faculty. The cloud-based health observing system can recognize crisis clinical circumstances and give biofeedback through early notice. This system empowers older patients to stay in contact with their families, and their families can generally comprehend their situation. This is a distant health checking gadget, it can get all the information and move the information to the cloud, which would then be able to be gotten to by its clinical supplier and authorized faculty[5]. These gadgets may build the shot at enduring unintentional sicknesses [6].

The accessibility of without and wireless sensor networks makes remote health monitoring possible. Body temperature and heart rate measurement. The device is an example of a wireless sensor utilized in medicinal equipment dobrescu and others. (2008) cited that the evolution of the different Internet facilities and without using wired sensors has opened up chances for healthcare [7]. Wireless sensor networks have many advantages when statistics gathering and observing services are feasible [8]. In health observing, this technology permits patients to observe their significant signs at home and wirelessly transmit the results to hospital professionals. In fact, before the patient needs emergency care, doctors can improve their ability to solve problems [9].

## II. LITERATURE REVIEW

### A. *The Architecture of the CoviDoor*

CoviDoor is a framework driven by Arduino, composed of integrated sensors, processors and communication devices. All these functions gather together to exchange and execute information from the climate. This standard of the Internet of Things [10] allows its administrators to remotely access gadgets through the remote cloud innovation to interconnect gadgets. These gadgets should have the advantage of the network so that they can talk to other smart gadgets without external mediation [11]. There are basically four design stages. Different stage perform various operations. Phase 1 includes how many gadgets are connected to obtain raw data that can be used for further analysis. Usually, it contains various sensors, which can be using wire or without wire. In the second stage, the group of relevant figures is accomplished so that it can be interrelated to the Internet. The

A to D conversion is started at this step. In the third step, the data pre-processing is performed through the IT system, and then enters the last step (stage 4), in which the filtered, analyzed, and processed the data which is kept in the cloud-based system[12] in the predictable back-end system [13].

### B. Standard of Photoplethysmography

The photoplethysmography procedure is the most cutting-edge strategies for estimating internal heat levels. The rule it uses is to transmit infrared light and receive infrared light after natural tissue reflects and retains the light. The light passing through the natural tissues may be consumed by various parts of the interior because certain iconic changes in the obtained light, which can be additionally checked to shield the pulse.

In order to execute the project without any system errors, make sure to calibrate each component separately beforehand. The different settings were merged together which achieve the main goal of the project “see Fig.1”. The following sections describe how to implement the entire project in turn, and then merge them together to achieve the final output [14].

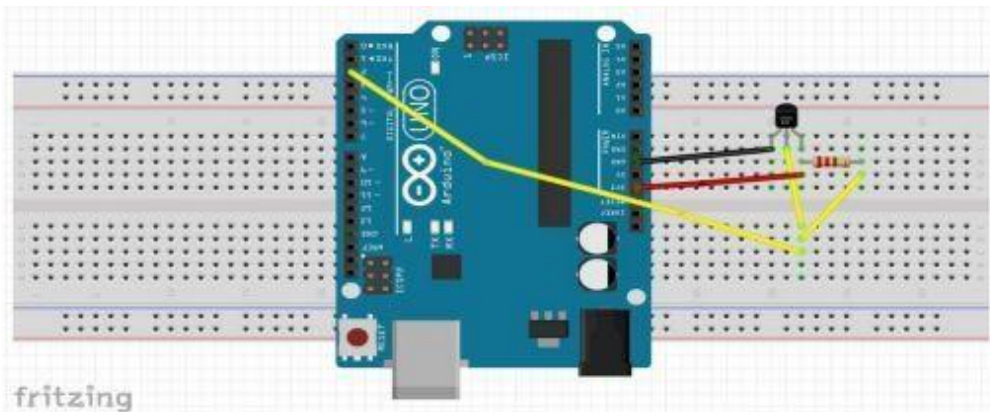

Figure 1. The body temperature measurement

#### *The body temperature measurement implementation:*

The body temperature at its best, to ensure that the body's enzymes work under the best conditions required. It can prevent the human body temperature from increasing or dropping to unhealthy levels, else, if the body temperature rises, it is not consistent, it will be fatal because the enzymes will not function properly “see Fig.2,”.

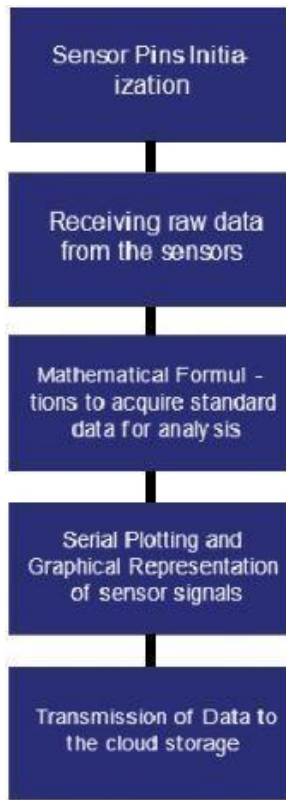

Figure 2. Circuit implementation of body temperature measurement

### III. METHODOLOGY

#### A. FUNCTIONS OF LM35 SENSOR

LM35 is a coordinated the temperature sensor. The yield voltage LM35 linear relative Celsius temperature, at standard temperatures, it can give  $\pm$ one forth  $^{\circ}\text{C}$  normal precision of room temperature without need extra alignment. The test utilized a LM35DZ-92 sort temperature sensor with plastic packaging. The pin limits as shown in figure 1, fundamental working limits are:

- Voltage: DC 4 ~ 30V
- Current which is less than 133  $\mu\text{A}$
- O/P voltage is + 6V to 1.0V
- O/P impedance is 1mA load 0.1ohm

- Accuracy is 0.5 °C (in + 25 °C)
- Leak current is > 60 uA
- Nonlinear value:  $\pm 1/4$  °C.

### B. Temperature Device

In this development, wired human temperature and heart rate sensors. This article just focuses on temperature sensors. In any case, both LM35 and TMP36 both are the appropriate for the estimation of the human body's internal heat level because of its higher precision and a wider range of partners, so LM35 has been selected. LM35 is a coordinated circuit temperature gadget. The yield voltage additionally has directly corresponding to Celsius temperature. The highlights of LM35 low yield impedance, adjusted straightforwardly in °Celsius (Centigrade) and direct + 10.0 mV/°C scale factor. It is additionally reasonable for far off applications. Table I shows the temperature reading with different method, Fig. 3 shows actual LM35 and its association.

TABLE I  
COMPARISONS OF THE TEMPERATURE READING (AVERAGE) WITH DIFFERENT METHOD.

Method	Temperature Reading (°C)	Percentage of Error (%)
Hand - digital thermometer	33.4	4.84
Hand – Temperature sensor	35.23	0.37

The voltage-temperature conversion basic formula for LM35 is given by, Temp in °C = [V Out in mV] / 10

### C. Data Processing Unit

Arduino is utilized to make association between measuring gadgets to constant checking database by means of wired associations.

LM35 was used for the main temperature monitoring device. Since, Test outcome demonstrations that the planned temperature sensor gives in a way that is improved than commercial computerized thermometer when the estimation is taken in the hand. Accordingly, hand temperature estimations

were considered in the investigations. Besides for a compact gadget, temperature is more helpful to be estimated close by.



Figure. 3 The LM35 (Texas Instruments)

Arduino IDE software was used to program the microcontroller (Arduino Uno) so that the signal from the temperature sensor can be represented in digital form.

The LM35 sensor is one of the qualities of this sensor is that it is sensitive. This sensor can be executed in different fields e.g. screen the temperature in concrete. The measure of warmth needs to oversee appropriately, one strategy to screen the temperature of the concrete during the solidifying cycle, the sensor utilized is LM35.

In this study, Manuel Ramos [15] used LM35 as one of the sensors utilized to check the excellence of concrete under heating conditions. Therefore, it can be seen from the system block diagram that the sensor used is a 2-32 LM35 sensor connected to the data gaining module. According to the analysis results, the different sensors used, so that the quality of the concrete can be understood.

The LM35 sensor is utilized to transform temperature into electricity. The input pin of the LM35 sensor is different from the DHT11 temperature and humidity sensor. The difference lies in the location of the input data. The theory of LM35 uses analog input data from the Arduino board, while DHT11 uses digital input data from the Arduino board, following the LM35 sensor in Fig. 4 [16].

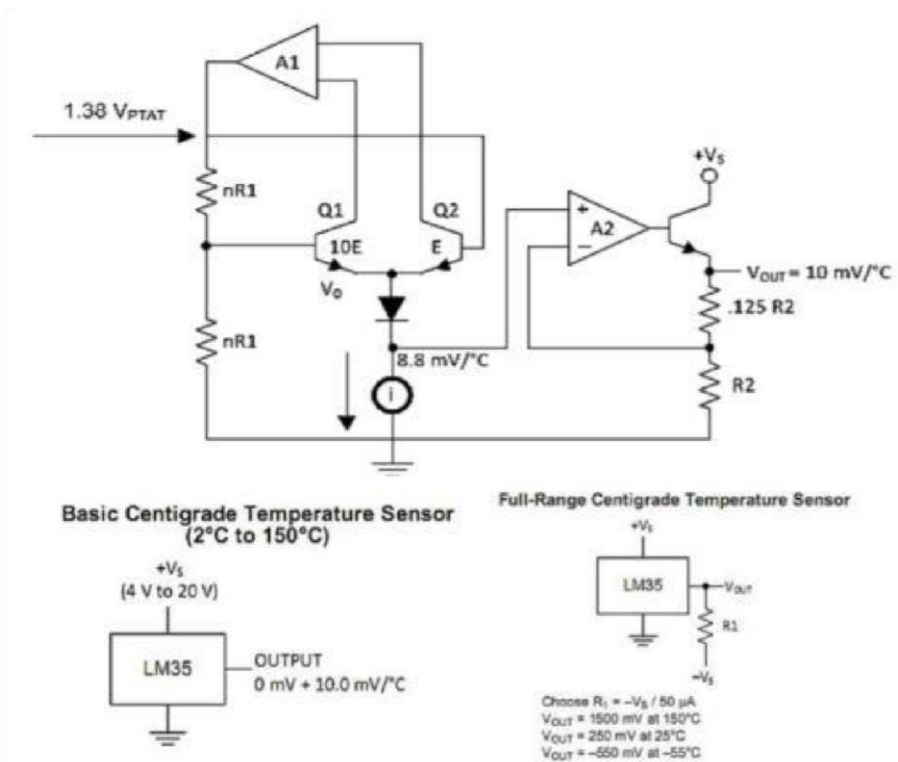

Figure 4. Schematic of LM35 sensor

#### IV. RESULT ANALYSIS

Primarily, the device was executed separately aimed at the observation of internal heat levels, but it can be used for heartbeat checks and galvanic skin reactions. For each internal heat level boundary, investigate the results obtained by changing behavior or ecological elements to improve the understanding of how the sensor works according to several changes. The above is a survey of signs procured and how they have been converged to move the information to the processor.

#### V. CONCLUSION

For the progress and progress of patients, the field of health has been constantly developing. Researchers and experts have been using the latest developments to make continuous improvements to bring such improvements into the field of well-being. In the long run, related innovations have always been the mainstream concern. This article leans toward the current demand for well-being-

based innovations that can be further developed into capabilities and solve the problems of unreliable people in society. A larger number of sensors is combined, such as respiratory rate sensors, pulse sensors and blood glucose sensors. These sensors can deliver a complete set of health observation frameworks for the purchasers of the project, because it can filter out the entire critical boundary of the human body. This can not only reduce the pressure of outpatient visits, reduce hospital costs and draw different conclusions, but also foresee the early occurrence of major diseases that may life security. This will be a main progress in this work and will have enormous and controllable influence on the well-being field.

The goal of this project has been effectively accomplished. Internal heat level estimation for far off wellbeing checking has been planned and created. The framework gives solid estimations and very easy to understand. The gadget and the framework can be worked on as far as estimating and joining between greater estimation gadgets, for instance, electrocardiography (ECG).

#### REFERENCES

- [1] Kamal, M. A., Alam, M. M., Khawar, H., & Mazliham, M. S. (2019, December). Play and Learn Case Study on Learning Abilities Through Effective Computing in Games. In 2019 13th International Conference on Mathematics, Actuarial Science, Computer Science and Statistics (MACS) (pp. 1-6). IEEE.
- [2] Jawbone Inc., "Jawbone fitness trackers," [Online]. Available: <https://jawbone.com/up/trackers> Accessed on 12th March 2018.
- [3] Fitbit Inc., "flex: Wireless activity + sleep wristband," [Online]. Available: <https://www.fitbit.com/flex> Accessed on 12th March 2018.
- [4] Apple Inc., "Apple watch," [Online]. Available: <https://www.apple.com/watch/>, Accessed on 12th March 2018.
- [5] Kamal, M. A., & Kamal, M. K. (2018). Context-Aware Perspective Analysis working of RFID Anti-Collision Protocols. *Journal of Independent Studies and Research Computing*, 16(2), 19-32.
- [6] Technology Intelligence, "8 Best Fitness Tracker" accessed April 2018. [Online]. Available: <https://www.telegraph.co.uk/technology/0/best-fitness-trackers-2017/> Accessed on 20th April 2018.
- [7] R. Dobrescu, D. Popescu, M. Dobrescu & M. Nicolae, "Intergration of WSN-based platform in a homecare monitoring system", *Latest Trends on Communications and Information Technology*, 2008, pp. 165-170.
- [8] E. Jovanov, A. Milenkovic, C. Otto & P. A. Groen, "A wireless body area network of intelligent motion sensors for computer assisted physical rehabilitation", *J. Neuroeng. Rehabil.*, 2005, vol 2.
- [9] A. H. Kiourmars & L. Tang, "Wireless Network for Haealth Monitoring Heart Rate and Temperature Sensor", *Fifth International Conference on Sensing Technology*, 2011, pp. 362-368
- [10] Raza, H. W., Kamal, M. A., Alam, M., & Su`ud, M. M. (2021). A Review of Middleware Platforms in Internet of Things: A Non-Functional Requirements Approach. *Journal of Independent Studies and Research Computing*, 18(1).

- [11] Kamal, M. A., Alam, M. M., & Mazliham, M. S. Routers Perspective Simulation-Based Analysis of EIGRP and OSPF Routing Protocol for an Organizational Model.
- [12] Kamal, M. A., Raza, H. W., Alam, M. M., & Su`ud, M. M. (2020). Highlight the features of AWS, GCP and Microsoft Azure that have an impact when choosing a cloud service provider. *International Journal of Recent Technology and Engineering (IJRTE)*.
- [13] "The 4 stages of an IoT architecture" [Online]. Available: <https://techbeacon.com/4-stages-iot-architecture> accessed on 31 July 2018.
- [14] Kamal, M. A. (2021). Arduino Controlled Spy Robo Car using Wireless Camera With live Streaming. arXiv preprint arXiv:2108.03402.
- [15] Zhiyu Li, Qiangui Xiao. "Design of temperature control system based on LM35 temperature sensor," *Micro computer information*, 20(9), 2004, pp. 51-52.
- [16] Manuel Ramos "Characterization of LM35 Sensor for Temperature Sensing of Concrete" *Proceedings of the International MultiConference Of Engineers and Computer Scientists 2017* , March 15 – 17, Hong kong Vol II, IMECS 2017
- [17] <http://www.ti.com/lit/ds/symlink/lm35.pdf> access date : 12 November 2018.

# Improvement of cardiovascular Diseases by Pine (Pinus) Nut Oil and its Alternatives

<sup>1</sup>Zartaj MALIK

<sup>1</sup>University of Engineering and Technology Lahore, Pakistan

**Abstract-** Pine nut oil and its alternatives are rich in fatty acids and important minerals. AAS was used to identify copper, zinc and iron, calcium, sodium, magnesium and potassium in oils. HPLC technique was applied to identify fatty acids and vitamin K. Then 5 groups of rats each having 5 rats were taken. One group was a controlled group with basic diet. Other four group were given high cholesterol diet for 20 days to increase their total cholesterol level (TC), low lipoprotein cholesterol level (LDL-C), high lipoprotein cholesterol level (HDL-C) and triglycerides (TGs). After 20 days, each group was fed basic diet with oil of 15mL. Second group was fed with 15mL/day pine nut oil (PNO), third group with 15mL/day pumpkin seed oil (PSO), fourth group was fed with 15mL/day walnut oil (WO) and fifth group was fed with 15mL/day sunflower oil (SO). After 4 weeks of this diet, the results were obtained that show the significant results. The present results revealed the decrease in low density lipoprotein cholesterol level, triglyceride, total cholesterol and increase in high density lipoprotein.

**Keywords:** Pine nut oil, walnut oil, pumpkin seed oil, sunflower oil, LDL-C, HDL-C, triglyceride, total cholesterol.

## I. INTRODUCTION

Pine nut oil and its three alternatives pumpkin seed oil, walnut oil and sunflower oil are rich source of carbohydrates, fats, protein, vitamins, minerals and water. Pine nut oil has been used for many years for healing illnesses and also for cooking. Pine nut oil is rich in vitamin E, vitamin K, copper, iron, manganese and especially monounsaturated fatty acids: the pinolenic acid. It is a rich source of carbohydrates like starch, sugars dietary fibers, fats like saturated, monounsaturated, polyunsaturated (linoleic acid, linolenic acid), protein, vitamins like thiamine, riboflavin, niacin, vitamin E, vitamin K, minerals like calcium, copper, iron, magnesium, potassium, zinc, manganese, phosphorus and water in dried form [1].

Pumpkin seed contains carbohydrates: sugars and dietary fibers, fats: saturated, monounsaturated, polyunsaturated, vitamins: Thiamine, riboflavin, niacin, vitamin C, vitamin E, vitamin K, folate, minerals: calcium, iron, magnesium, manganese, phosphorus, potassium, sodium, protein, zinc and water [2]. It contains antioxidants, high fiber, fatty acids, zinc and magnesium that reduce high blood

pressure and high bad-cholesterol level. It contains antioxidants to reduce inflammation. It contains antioxidants to reduce inflammation. It is beneficial for hair growth, skin health, eye health, urinary health, sexual health status, pregnancy, insomnia prevention, improve immune system, and improve digestion and weight loss [3].

Walnut oil contains high percentage of alpha-linolenic acid that reduces inflammation and improves blood fat composition. Fatty acids in walnut oil lowers bad-cholesterol level, reduces inflammation and improve blood vessel function [4]. Sunflower oil contains fatty acids: oleic acids and linoleic acids are in high quantity, vitamins: vitamin E, vitamin k etc [5]. Sunflower oil good to control the bad-cholesterol level in the blood and prevent from heart diseases. These oils are examined for treatment of cardiovascular disease [6].

Some important unsaturated fatty acids which are very effective for fats release are alpha-linolenic acid, linoleic acid and oleic acid. Alpha linolenic acid ( $C_{18}H_{30}O_2$ ) is unsaturated fatty acid and is named as omega-3. Its intake is beneficial for heart diseases. It shows the effects on heart by reducing cardiac attack, reduces clot formation (thrombosis), decreases triglyceride level, reduce the blood pressure and inflammation too. Linoleic acid ( $C_{18}H_{32}O_2$ ) is a polyunsaturated fatty acid and named as omega-6. It reduced the total cholesterol level and LDL level that causes blood pressure, and affects the heart muscles [7]. Oleic acid ( $C_{18}H_{34}O_2$ ) is also unsaturated fatty acid and named as omega-9 because double bond is present at carbon number 9. It is also useful for reducing the blood pressure, improving HDL level and decreases the LDL level in blood [8]. Vitamin K as a whole is an antioxidant and control the calcium deposition in the walls of arteries. Vitamin K1 deficiency causes the bleeding in gum, nose bleeds, anemia and coronary heart disease [9]. Likewise, some metals are present in the oils that show the effects on the heart. Calcium ions works as an electrolyte and beneficial for blood cells and circulatory system. Studies revealed that the calcium ion is used for the contraction of all the muscles by passing the electrical signals from one cell to other cell [10]. Sodium is present in the blood and blood cells and maintains the volume of the blood in the body. When body loses the balance of sodium in the blood, high or low blood pressure causes [11]. Potassium controls the blood pressure and bad cholesterol. If its concentration is lower in the blood it may lead to disturbance of heart beat and may causes diseases [12]. Magnesium acts as guard for entrance and exit of calcium in muscle cells. Due to the electrolytes in blood magnesium concentration decreases in the blood and may cause cardiovascular disease and hypertension [13]. Copper in the blood also affects the heart. Low level of copper level causes the high cholesterol level

and high blood pressure. Due to its deficiency, change the structure and function of blood cells [14]. Zinc regulates the calcium in the heart cells and works as antioxidant. If the zinc amount decreases then calcium releases in excessive amount that cause the heart failure [15]. Iron is an important element of hemoglobin that forms the blood. When the iron level decreases, the blood level also decreases and oxygen intake becomes low then heart beat becomes irregular. Sometimes angina causes or heart failure occurs [16].

A. *Material and methods*

Pine nut oil was purchased from SAC manufacturer Karachi, pumpkin seed oil and walnut oil were purchased from local market in Lahore. While sunflower oil was purchased from Bio Hunza manufacturers, Islamabad, Pakistan. Nitric acid, Sulfuric acid, Ethanol and Potassium hydroxide were purchased from sigma Aldrich Company.

B. *Experiment*

Some effective metals, vitamin and unsaturated fatty acids present in oils were detected by different techniques in PCSIR Lahore. While the experiments on rats and their results identifications were done in University of veterinary and animal sciences, Lahore, Pakistan.

C. *Metals detection through AAS:*

*Sample preparation:*

In determination of Cu, Fe, Zn, Ca, Mg, Na and K, the sample was prepared to run in AAS. 3ml of sample oil was taken in beaker and added 10ml HNO<sub>3</sub> through pipette in it. Then heated sample for few minutes till fumes start evaporation. Then 10ml HNO<sub>3</sub> was added in solution. Again fumes formed on heating. Then 20ml of distilled water was added in the beaker. When sample started boiling, 50ml warm distilled water was added. Then remove from sand bath and blown out the lamp. Then the sample was filtered through the filter paper. Then 5ml filtrate was taken and put the water of 100ml volumetric flask. These samples were determined through AAS.

*AAS technique:*

AAS was run by inserting the sample and required conditions. The prepared sample was added in the injector that was injected in the sample cell. Then process was started by pressing the buttons to start the automated instrument. The source hollow cathode lamp emitted the rays of specific range. The column contains sample medium and reference medium with chopper and mirrors for separation of rays. The rays came from source, reached to the beam splitter that split the rays and sent them to the reference cell and sample cell. Then beams passed through the sample cell and the reference cell that contained the sample and standard. The sample absorbed some specific rays and transmitted

others. While all the rays of reference cell were transmitted as it is. Then rays reached to beam splitter that sent the emitted light one by one towards the Monochromator came from sample medium and reference cell. Then Monochromator sent the rays one by one to the amplifier that amplifies the rays and help to separate all the rays from other rays appeared on graph. Then these rays moved towards detector that is attached to the computer. The detector after reading the rays gave the results on the computer in the form of peaks. Graph contained calibration curve that explained the amounts of metals present in the oils.

#### *D. Fatty acids and vitamin K detection through HPLC:*

##### *Sample preparation:*

2g of all liquid oil samples were taken in 250 mL round bottom flask separately and dissolved them in 50ml of 0.5M KOH alcohol solution. Then all oil samples were put in water bath and heated with occasional stirring at 80°C for 1 hour. After heating, all oil samples were cooled in 500ml flask. Then 25ml of sulfuric acid was added to make solution lightly acidic.

#### *E. HPLC technique:*

##### *Lipoprotein test:*

This test was done on rats. Twenty five male rats of weighing  $190 \pm 10$ gm and 10 to 16 weeks old were purchased and placed in controlled environment of light, temperature and humidity. Rats were fed with the diet containing nutrients required for good health.

*Basel diet:* The diet contained 3% fat, 2% cholesterol and basic nutrients. They were placed in light for 12 hours and 12 hours in dark.

*Normal Diet:* They were fed with basic diet and water for a week before experiment. After one week, the low density lipoprotein cholesterol and high density lipoprotein cholesterol level were measured. The all required cholesterol level, triglyceride level; HDL-C and LDL-C levels were in controlled range as before. Then rats were divided into five groups and each has five rats. First group of rats was taken as controlled group and fed with basic diet and pure water.

*Hypercholestermic diet given to rats:* All other four groups of rats were fed with high fat and cholesterol containing diet for twenty days. After twenty days, the heart beat of rats were high and unequal. Then blood was tested to check the levels of TC, TGs, LDL-C and HDL-C. The level of LDL-C was increased and HDL-C level was decreased in high quantity. Then these rats were kept for a week in standard conditions for stabilizing the blood cholesterol level. After one week, the

cholesterol levels were again checked and resulted in high levels as before one week. Then these rats were taken for the experiment. The all other four groups were taken as positive.

*Hypercholestermic rats groups fed with different oils:* The second group was fed with addition of 15mL pine nut oil in basic diet three times a day. Third group was fed with addition of 15mL pumpkin seed oil in basic diet. Fourth group was fed with addition of 15mL walnut oil in basic diet and fifth group was fed with addition of 15mL sunflower oil in basic diet three times a day. After 4 weeks, again blood tests were done. The results obtained were different due to the linolenic acid and linoleic acid quantities in all four oils.

## II. Results and Discussion:

### A. AAS result:

AAS gave the results for the detection of minerals in the oils that were affecting the heart muscles and their regulations of ions to make smooth muscles and blood circulation.

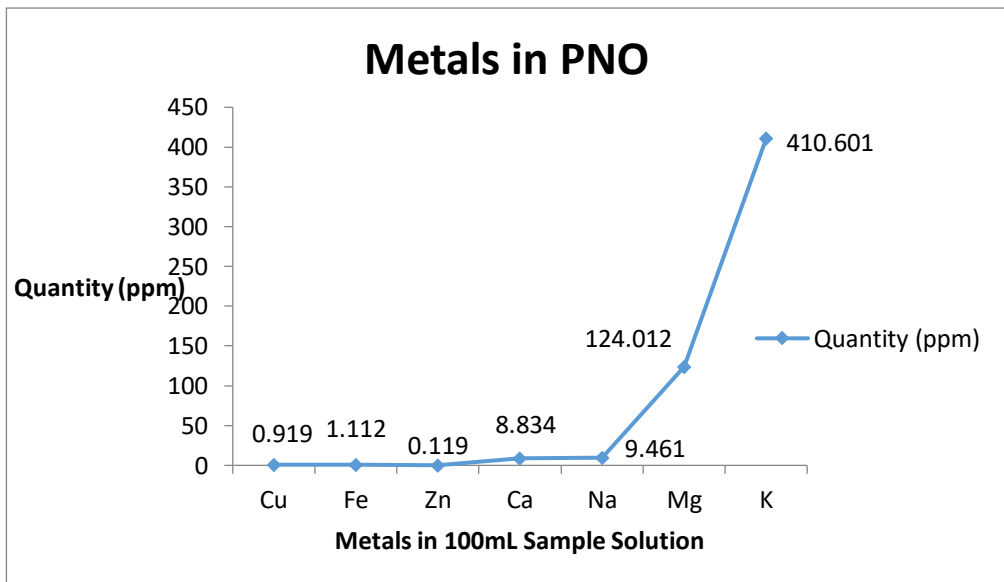

Fig. 1 Metals in PNO

In fig.1 100mL solution of oil, copper was 0.919ppm, iron was 1.112ppm, zinc was 0.119ppm, calcium was 8.834ppm, sodium was 9.461ppm, while magnesium was 124.012ppm and potassium was 410.061ppm in quantity.

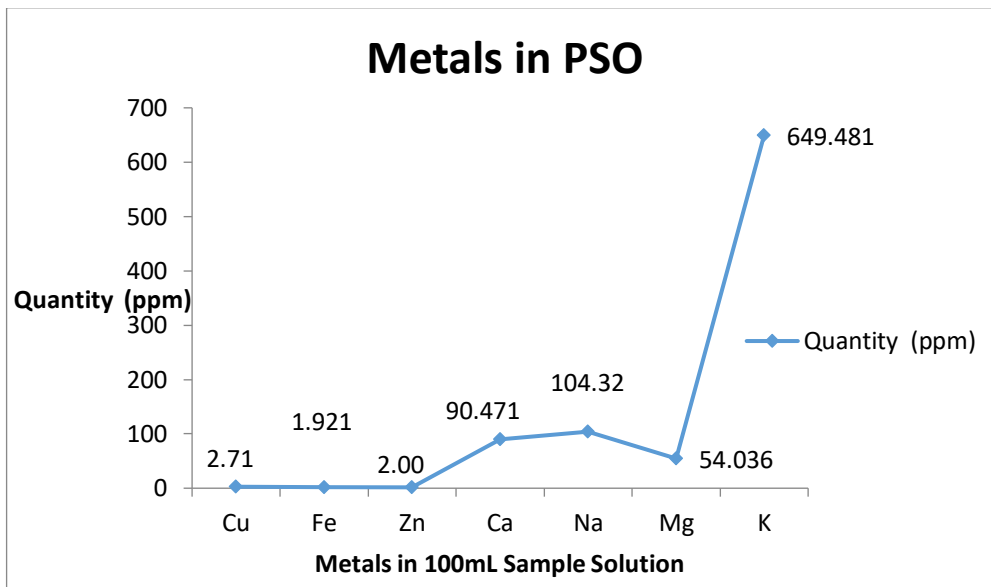

Fig. 2 metals in PSO

In fig. 2 AAS experiment was applied on 100mL pumpkin seed oil sample solution and resulted in the graph of the detected metals quantities; Copper 2.71ppm, iron 1.921ppm, zinc 2.00ppm, calcium 90.471ppm, sodium 104.32ppm, magnesium 54.036ppm and potassium 649.481ppm.

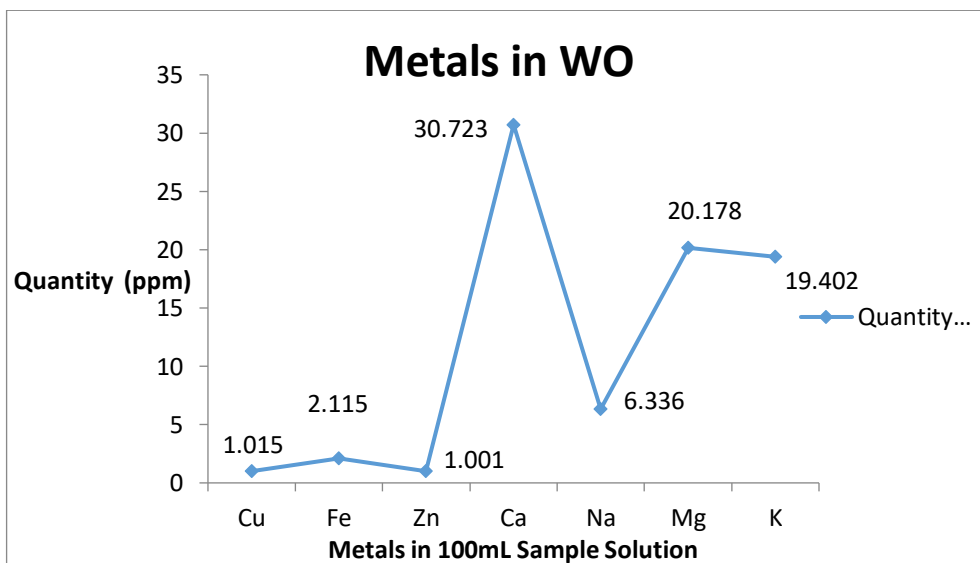

Fig. 3 Metals in WO

After AAS experiment on 100mL sample solution following quantities of metals were obtained and shown in fig. 3. Copper 1.015ppm, iron 2.115ppm, zinc 1.001ppm, calcium 30.723ppm, sodium 6.336ppm, magnesium 20.178ppm and potassium 19.402.

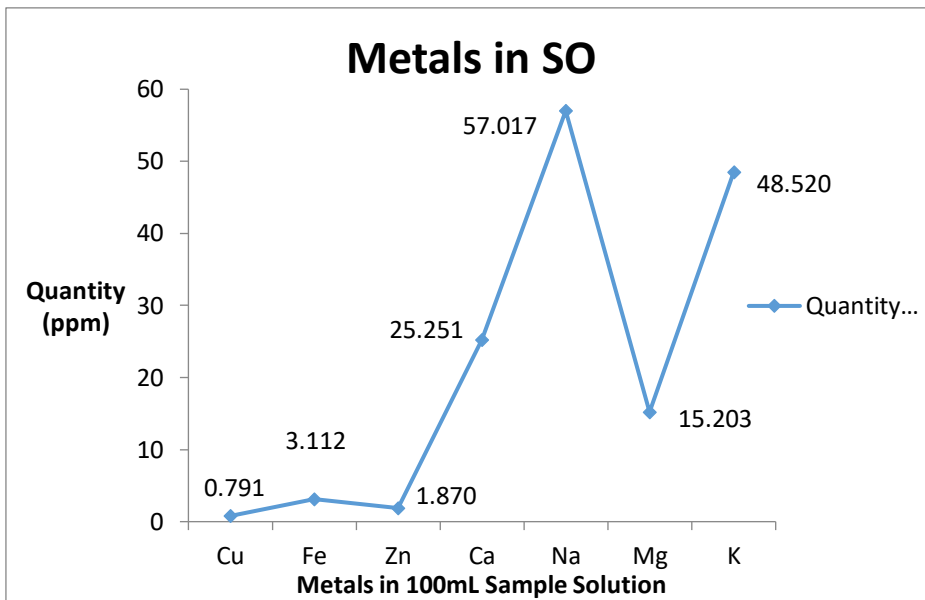

Fig. 4 Metals in SO

The results were obtained in parts per million that are: calcium 0.791ppm, iron 3.112ppm, zinc 1.870ppm, calcium 25.251ppm, sodium 57.017ppm, magnesium 15.203ppm and potassium 48.520ppm and shown in fig. 4.

**B. HPLC result:**

Oleic acid (C<sub>18:1</sub>):

The quantity of oleic acid present in the pine nut oil, pumpkin seed oil, walnut oil and sunflower oil was identified by HPLC and shown in fig. 5. PNO contains 28.3, PSO contains 30.5, WO contains 20.2 and SO contains 43.9 oleic acid.

Linoleic acid (C<sub>18:2</sub>):

Linoleic acid is present in the pine nut oil, pumpkin seed oil, walnut oil and sunflower oil. PNO contains 44.5, PSO contains 46.5, walnut oil contains 54.6 and sunflower oil contains 42.8 linoleic acid. These quantities are expressed in figure 6.

#### Alpha-linolenic acid ( $C_{18:3}$ ):

Different values of linolenic acid are detected from the oils by HPLC. PNO contains 17.0, PSO contains 6.4, WO contains 15.0 and SO contains 3.5 alpha-linolenic acid as expressed in fig. 7.

#### Vitamin K (Phylloquinone):

Pine nut oil, pumpkin seed oil, walnut oil and sunflower oil has different values of phylloquinone measured by HPLC and expressed with the graph in figure 8. PNO contains 49.52, PSO contains 84.01, WO contains 3.68 and SO contains 1.82.

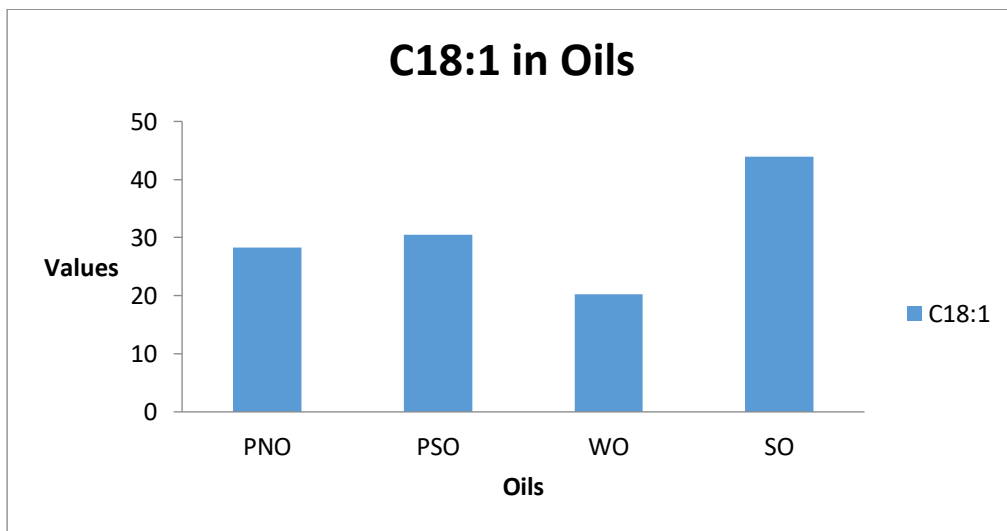

Fig. 5 Oleic acid in Oils

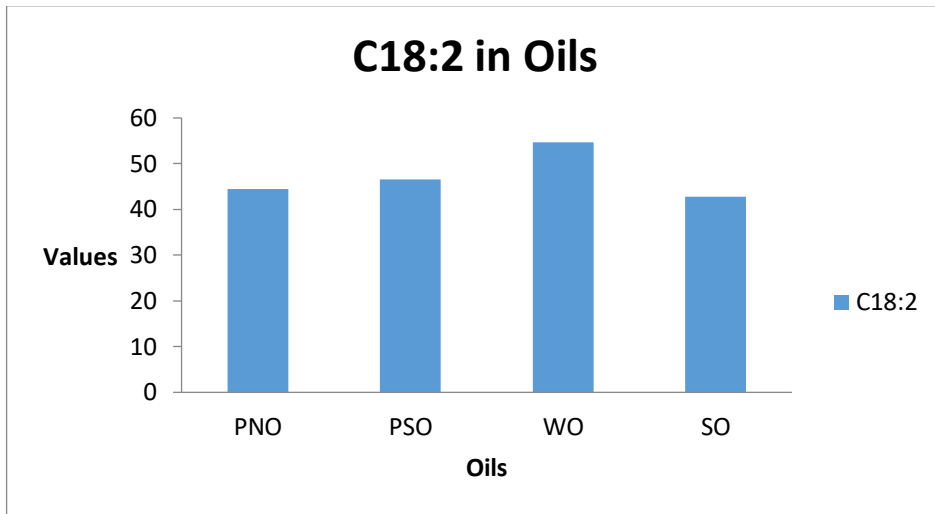

Fig. 6 LA in Oils

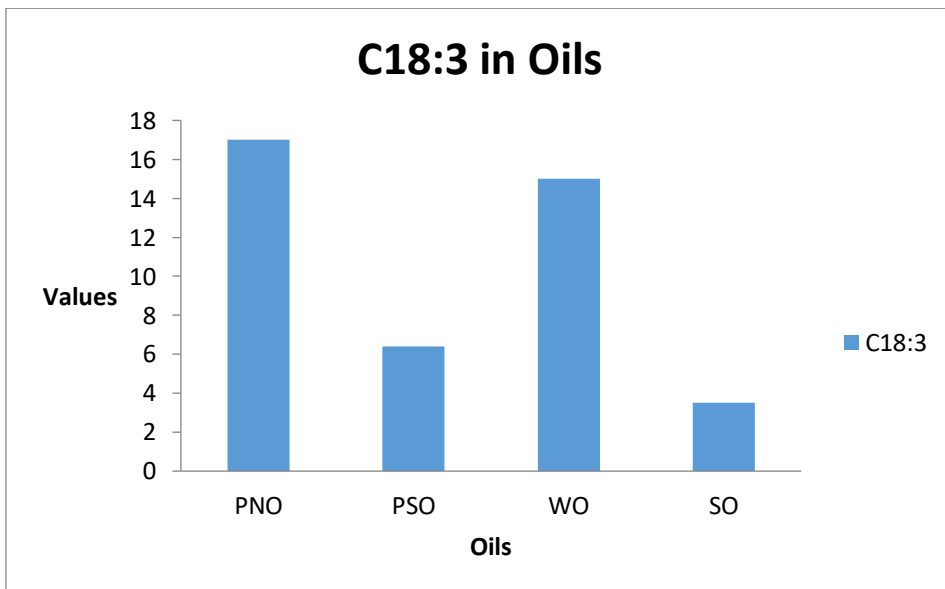

Fig. 7 ALA in Oils

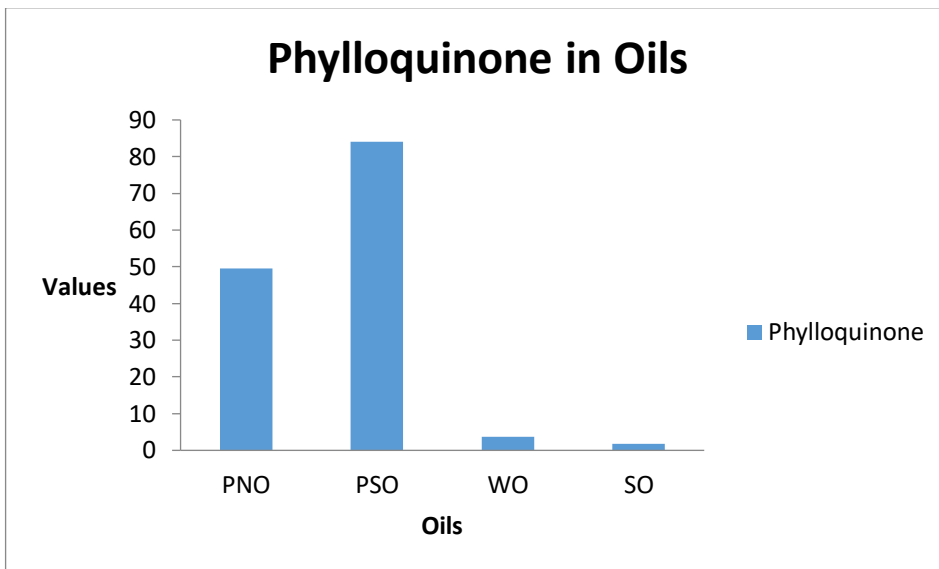

Fig. 8 Phylloquinone in Oils

*C. Lipoprotein result:*

After 4 weeks of this diet, the results were obtained that show the significant results. TC of controlled group  $110.20 \pm 5.80$ , positive group  $150.38 \pm 8.72$ , PNO  $113.75 \pm 2.31$ , PSO  $116.78 \pm 5.56$ , WO  $115.27 \pm 9.29$ , SO  $119.74 \pm 8.23$ , HDL-C of controlled group  $48.49 \pm 3.62$ , positive group  $40.86 \pm 2.25$ , PNO  $50.24 \pm 1.71$ , PSO  $47.89 \pm 0.74$ , WO  $49.18 \pm 3.39$ , SO  $41.42 \pm 6.26$ , LDL-C of controlled group  $77.05 \pm 9.89$ , positive group  $120.71 \pm 4.39$ , PNO  $78.40 \pm 2.16$ , PSO  $81.19 \pm 5.44$ , WO  $72.30 \pm 9.91$ , SO  $91.90 \pm 3.51$ , TGs of controlled group  $80.67 \pm 5.43$ , positive group  $96.63 \pm 6.62$ , PNO  $79.35 \pm 3.52$ , PSO  $86.25 \pm 4.20$ , WO  $70.80 \pm 4.11$ , SO  $75.03 \pm 5.02$ . The comparison of these oils results are shown in table 1 and graphically in figure 9.

**Table 1 Comparison of Lipoprotein test results of all Oils**

Groups	TC mg/dL	HDL-C mg/dL	LDL-C mg/dL	TGs mg/dL
Controlled group	$110.20 \pm 5.80$	$48.49 \pm 3.62$	$77.05 \pm 9.89$	$80.67 \pm 5.43$

<b>Positive group</b>	150.38±8.72	40.86±2.25	120.71±4.39	96.63±6.62
<b>PNO</b>	113.75±2.31	50.24±1.71	78.40±2.16	79.35±3.52
<b>PSO</b>	116.78±5.56	47.89±0.74	81.19±5.44	86.25±4.20
<b>WO</b>	115.27±9.29	49.18±3.39	72.30±9.91	70.80±4.11
<b>SO</b>	119.74±8.23	41.42±6.26	91.90±3.51	75.03±5.02

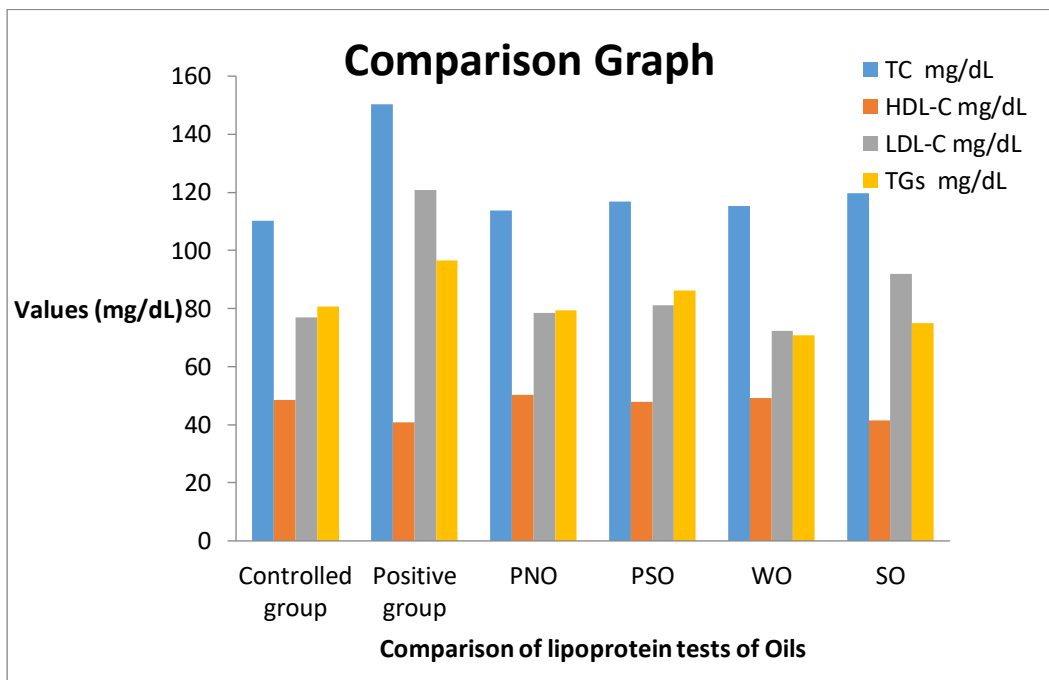

Fig. 9 Comparison of Lipoprotein test of all Oils

### III. Discussion:

The present study is to know the effects of pine nut oil, pumpkin seed oil, walnut oil and sunflower oil at the different levels on the rats having high fats level. After 4 weeks of this diet, the results were obtained that show the significant results. TC of controlled group 110.20±5.80, positive group 150.38±8.72, PNO 113.75±2.31, PSO 116.78±5.56, WO 115.27±9.29, SO 119.74±8.23, HDL-C of controlled group 48.49±3.62, positive group 40.86±2.25, PNO 50.24±1.71, PSO 47.89±0.74, WO

49.18±3.39, SO 41.42±6.26, LDL-C of controlled group 77.05±9.89, positive group 120.71±4.39, PNO 78.40±2.16, PSO 81.19±5.44, WO 72.30±9.91, SO 91.90±3.51, TGs of controlled group 80.67±5.43, positive group 96.63±6.62, PNO 79.35±3.52, PSO 86.25±4.20, WO 70.80±4.11, SO 75.03±5.02.

This study revealed the major finding of decrease in LDL-C level and improvement of HDL-C level in blood causes the decrease in blood pressure; relax the muscles of arteries and heart. The heart beat became smooth and walls of vessels became wide by dissolving the fats deposited in them.

#### IV. Conclusion and Future research direction:

The present results revealed the antioxidant and anti-inflammatory effects of pine nut, pumpkin seed, walnut and sunflower oil. These oils show effect on the cholesterol levels causes the walls of vessels fat free and makes the heart vessels wide and blood flow easily and smoothly. These oils help to reduce the risk factors of cardiovascular diseases.

These oils can be mixed in their different percentage compositions and their composition results will be examined not just for heart diseases but can also be studied for other major organs like stomach.

#### ACKNOWLEDGEMENT

First and foremost, I am thankful to my Creator Almighty Allah for giving me the functioning body and mind in order to live life and learn, and Showers His blessings to complete this research successfully.

It is a genuine pleasure to express my deep sense of thanks and gratitude to my gracious and experienced Supervisor Dr. Habib Hussain for his dedication and keen interest above all his overwhelming attitude to help his students and mainly responsible for completing my work.

I owe a deep sense gratitude to Prof. Dr. Rubina Gillani (Chairperson of Department of Chemistry, UET Lahore) for her keen interest on me at every stage of my research. Her prompt inspirations, timely suggestions with kindness, enthusiasm and dynamism have enabled me to complete my thesis.

I thank profusely to Dr. Imran Kaleem for his kind help and corporation throughout my research work. His scholarly advice and scientific approach have helped me to very great extent to accomplish this task.

I offer my special thanks to my friends Ms. Atiq Perveez, Ms. Khudeja and Ms. Saima Razzaq for their corporation and lovely attitude during my study at University.

I am extremely grateful to my mother for her love, prayers, caring and sacrifices for educating and preparing me for my future. Also, I express my thanks to my siblings for their support and valuable prayers.

## REFERENCES

- [1] Deineka V I, Deineka L A (2003). Triglyceride composition of *Pinus sibirica* oil. *Chem Net Compd* 39(2): 171-173
- [2] Alfawaz, M. A. (2004). Chemical composition and oil characteristics of pumpkin (*Cucurbita maxima*) seed kernels. *Food Science and Agriculture*, 2(1), 5-18.
- [3] Procida, G., Stancher, B., Cateni, F., & Zacchigna, M. (2013). Chemical composition and functional characterisation of commercial pumpkin seed oil. *Journal of the Science of Food and Agriculture*, 93(5), 1035-1041.
- [4] Martínez, M. L., Labuckas, D. O., Lamarque, A. L., & Maestri, D. M. (2010). Walnut (*Juglans regia* L.): genetic resources, chemistry, by-products. *Journal of the Science of Food and Agriculture*, 90(12), 1959-1967.
- [5] Grompone, M. A. (2011). Sunflower Oil. *Vegetable Oils in Food Technology: Composition, Properties and Uses*, 137-167.
- [6] Bamgboye, A. I., & Adejumo, A. D. (2007). Development of a sunflower oil expeller. *Agricultural Engineering International: CIGR Journal*
- [7] Voet, Judith G., Voet, Donald. (2004). *Biochemistry*. New York, NY: J. Wiley & Sons. pp. 496-500.
- [8] Terés, S., Barceló-Coblijn, G., Benet, M., Alvarez, R., Bressani, R., Halver, J. E., & Escriba, P. V. (2008). Oleic acid content is responsible for the reduction in blood pressure induced by olive oil. *Proceedings of the National Academy of Sciences*, 105(37), 13811-13816.
- [9] Fusaro, M., Gallieni, M., Rizzo, M. A., Stucchi, A., Delanaye, P., Cavalier, E., ... & Fabris, F. (2017). Vitamin K plasma levels determination in human health. *Clinical Chemistry and Laboratory Medicine (CCLM)*, 55(6), 789-799.
- [10] Sutanto, H., & Heijman, J. (2019). The Role of Calcium in the Human Heart: With Great Power Comes Great Responsibility. *Frontiers for Young Minds*, 7(65).
- [11] O'Donnell, M., Mente, A., & Yusuf, S. (2015). Sodium intake and cardiovascular health. *Circulation research*, 116(6), 1046-1057.
- [12] Castro, H., & Raij, L. (2013, May). Potassium in hypertension and cardiovascular disease. In *Seminars in nephrology* (Vol. 33, No. 3, pp. 277-289). WB Saunders.
- [13] Jahnen-Dechent, W., & Ketteler, M. (2012). Magnesium basics. *Clinical kidney journal*, 5(Suppl\_1), i3-i14.
- [14] Saari, J. T. (2000). Copper deficiency and cardiovascular disease: role of peroxidation, glycation, and nitration. *Canadian journal of physiology and pharmacology*, 78(10), 848-855.
- [15] Turan, B., & Tuncay, E. (2017). Impact of labile zinc on heart function: from physiology to pathophysiology. *International journal of molecular sciences*, 18(11), 2395.

- [16] Walther, C. P., Triozzi, J. L., & Deswal, A. (2020). Iron deficiency and iron therapy in heart failure and chronic kidney disease. *Current Opinion in Nephrology and Hypertension*, 29(5), 508-514.

# INVESTIGATION INTO THE PERFORMANCES OF SUPERVISED LEARNING ALGORITHMS IN DIFFERENT PHISHING DATASETS

<sup>1</sup>Oyelakin A. M., <sup>2</sup>Olatinwo I. S., <sup>3</sup>Rilwan D. M., <sup>4</sup>Azeez R. D., <sup>5</sup>Obiwusi Y. K.

<sup>1</sup>Department of Computer Science, Faculty of Natural and Applied Sciences

Al-Hikmah University, Ilorin, Nigeria

<sup>2</sup>Department of Computer Science, Federal Polytechnic, Offa, Nigeria

<sup>3</sup>Department of Computer Science, Sheu Idris College of Health Sciences and Technology, Makarfi, Nigeria

<sup>4</sup>ICT Unit, Al-Hikmah University, Ilorin, Nigeria

<sup>5</sup>Department of Mathematics and Computer Science, Summit University, Offa, Nigeria

**Abstract-** Phishing techniques are employed by attackers to obtain the sensitive and confidential information of unsuspecting internet users. To stem the tide of phishing-based attacks in the cyber space, different machine learning techniques have been proposed as better alternatives to the signature-based approaches. This study used a different approach in the detection of phishing evidence in three phishing datasets. The focus of the study is to investigate the performances of Random Forest, K-Nearest Neighbour and Extra Tree algorithms in three different phishing datasets. The first two datasets of different sizes and features were obtained from Machine Learning UCI repository while the third dataset was collected from Mendeley. Exploratory Data Analysis was carried out in order to understand the nature of the features in the three datasets. Then, minimal dataset pre-processing was carried out on the features. A filter-based feature selection method called ANOVA F-test was used to select promising features that can improve classification performances of the selected learning algorithms. From all the experimental analyses, findings revealed that Random Forest has the overall best performances compared to the two other classifiers. Moreso, all the three algorithms had best average performances in the four metrics in the dataset provided by Tan (2018). The comparative technique used in this study is believed to help provide further insights in phishing detection researches.

**Keywords:** Phishing Classification, Phishing Datasets, Cyber Space Attacks, Learning Algorithms

## I. INTRODUCTION

As an evidence that phishing-based attacks are growing in unprecedented rate, APWG Fourth Quarter report of 2020 [1] claimed that there is a double increase in phishing attacks. Attackers

---

[amoyelakin@alhikmah.edu.ng](mailto:amoyelakin@alhikmah.edu.ng)

use uniform resource locators or infected file attachments to launch phishing-based attacks. Malicious cyber actors are not relenting in their efforts to launch attacks in the internet space. The financial institutions, webmail, and SaaS site category was the one most frequently victimized by phishing in the fourth quarter of 2020 [1].

Phishing attacks keep using an array of deception techniques to fool users. These include domain names chosen to avoid detection encryption designed to lull victims into a false sense of security. Various machine learning-based approaches have been identified to be promising for identification of cyber threats [2]. One of the key challenges in phishing study is the availability of benchmark datasets that is generally acceptable. This study focuses on investigating the performances of some supervised learning algorithms across three different phishing url datasets. The motive behind this is to provide further insights in phishing-based studies.

As reported in different literature, examples of supervised machine Learning algorithms that can be used for classification or regression tasks include: Random Forest Algorithm, Support Vector Machines, K Nearest Neighbour, ExtraTrees Algorithm, Adaboost, Voting Classifier, XGBoost and so on. It has been argued that the ensemble classifiers are generally more accurate than any of the individual classifiers ([3];[4];[5];[6];[7]). This study changed the direction of comparative studies of machine learning classifiers in phishing detection. The focus of this study is to properly identify phishing evidence from each of the datasets using Random Forest Algorithm, K-Nearest Neighbour and Extra Tree Algorithm. Thereafter, the comparisons of the algorithms are carried out in respect of each of the datasets.

## II RELATED STUDIES

Writers in[8]built machine learning-based models for the prediction of phishing-based attacks. The algorithms used for building the models include: Logistic Regression, Support Vector Machines (SVM), Decision Trees and Neural Networks. The authors used a phishing dataset collected from UCI Machine Learning repository. Accuracy, sensitivity and specificity were used as metrics. The paper reported that Support Vector Machine has the largest performance by achieving 89.84% of accuracy, 93% of specificity and 89% of sensitivity. These results can be said to be low in view of the need to detect every phishing attack in the internet space.

Similarly, the researcher in [9] provided promising evidence for the use of machine learning techniques for botnet detection. The paper provided empirical results from the proposed machine learning methods used for phishing attacks classification. The performances of the selected machine learning algorithms were compared. Authors in [10] carried out a comprehensive review of literature on phishing attack detection. The study focused on the need to provide anti-phishing training for online users with a view to stemming the tide of phishing based attacks. However, the work only focused on comparative literature review without the need to develop anti phishing solution.

Authors in [11] developed machine leaning based phishing detection models that were validated using a phishing dataset. The focus of the work is to identify how the selected leaning algorithms behave in the only dataset used for the experimentations. Similarly, researchers in [12] built a model for the classification of phishing attacks. The authors focused on the evaluation of the chosen classifier using only accuracy at the detriment of other useful metrics. Thus, erroneous judgments were arrived at in the phishing classification. Authors in [13]used five different machine learning algorithms for the classification of malicious urls. The authors used only three

performance metrics for the evaluation of the selected algorithms. Unlike the approach in this study, emphasis was not on comparison of the performances of single and ensemble classifiers.

### III METHODOLOGY

The methodology used in this work is machine learning-based. The methodology is divided into various stages, which include: data collection, data cleaning, feature selection, and phishing classification using the selected algorithms. The processes are briefly discussed below.

#### Datasets Collection Process

The first two datasets were obtained from UCI Machine Learning repository while the third one was downloaded from Mendeley data. The datasets were obtained through the links provided herein. For instance, the first dataset in the table 1 is publicly available at <https://archive.ics.uci.edu/ml/machine-learning-databases/00379/> as released by [14]. Furthermore, the dataset in table 1 with serial number 2 was obtained from <https://archive.ics.uci.edu/ml/machine-learning-databases/00327/> as made available by [15]. The third dataset which is a phishing dataset released by [16] is available at <http://dx.doi.org/10.17632/h3cgnj8hft.1>. The characteristics of the datasets are as shown in table 1. Exploratory Data Analysis was then carried out in order to understand the nature of the features in the three datasets.

#### About the Datasets

**Table 1: Characteristics of the Datasets used**

S/N	Dataset Author/Year	No of Input Features	Number of Instances	Missing values?	Data type of Features (Input and Target)
1	Abdelhamid et al. (2014) [14]	9	1353	No	The input features are integer type while the target feature is categorical.
2	Mohammad, McCluskey and Thabtah (2014) [15]	30	11054	No	The input features are integer type while the target feature is categorical
3	Tan (2018) [16]	48	10,000	No	The input features are numeric (integer and floating point) while the target feature is categorical.

#### Data Preprocessing and Feature Selection Method Used

The data pre-processing steps carried out in this study are meant to make the features in the dataset to be in usable format for the learning algorithms. This is in learning with the argument by [17] on the need to pre-process features to be used for building machine learning models. First

of all, summary statistics was used to ascertain the kind of statistical description contained in each of the datasets. Moreover, the multi-class nature of first dataset was addressed using One-Over-the-Rest technique. Thus, the target variable was turned to binary (phishing and non-phishing). The two other datasets have binary classes by default.

Then, the values in the input features of the datasets were scaled using min-max scalar so as to improve the performances of the proposed learning algorithms. Generally, the formal description of scaling features in a dataset is as follows: Let  $x$  be an individual feature value (i.e., a value of the feature in some data point), and  $\min(x)$  and  $\max(x)$ , respectively, be the minimum and maximum values of this feature over the entire dataset. Min-max scaling technique is used to squeeze (or stretch) all feature values to be within the range of  $[0, 1]$ .

Mathematically, min max normalisation is:  $X_{\text{norm}}=(X-X_{\text{min}})/X_{\text{max}}-X_{\text{min}}$  (1)

Thereafter, ANOVA F-score technique was used for selecting most promising features in each of the datasets. The choice of the feature selection method is based on the numerical data as input feature and categorical data as target class. Generally, feature selection is the process of reducing the number of input variables when developing a predictive model [17]. The features with the high scores were taken to be promising for the training of the models.

## Experimental Analyses

### Working Environment

The working environments in this study are: hardware and software environments. Several runs were carried out during the experimentation and the results obtained are reported in this section.

### Hardware

The hardware configuration of the system used for the predictive analysis is as follows: Dual core processor, 4GB RAM, and 500 GB Hard Disk Drive.

### Software

The softwares include: Windows 10, Anaconda Python IDE with Python 3.7.2 version and libraries such as Pandas, Sklearn, Numpy and Scipy.

### Metrics for Evaluation

The mathematical formulae used for obtaining the values of the performance metrics are:

$$\text{Accuracy}=(\text{TP}+\text{TN})/(\text{TP}+\text{TN}+\text{FP}+\text{FN}) \quad (2)$$

$$\text{Precision}=\text{TP}/(\text{TP}+\text{FP}) \quad (3)$$

$$\text{Recall}=\text{TP}/(\text{TP}+\text{FN}) \quad (4)$$

$$\text{F1-score}=2 \times (\text{Precision} \times \text{Recall})/(\text{Precision} + \text{Recall}) \quad (5)$$

#### IV RESULTS AND DISCUSSION

Table 2: Summary Statistics of the three datasets

S/N	Summary Statistics of the Datasets				
1	1	-1	...	0	0.1
	count	1352.000000	1352.000000	...	1352.000000
		1352.000000			
	mean	0.237426	-0.258136	...	0.114645
					-
		0.113905			
	std	0.916493	0.679024	...	0.318711
					0.955121
	min	-1.000000	-1.000000	...	0.000000
					-1.000000
	25%	-1.000000	-1.000000	...	0.000000
					-1.000000
	50%	1.000000	0.000000	...	0.000000
					-1.000000
	75%	1.000000	0.000000	...	0.000000
					1.000000
	max	1.000000	1.000000	...	1.000000
					1.000000
2	-1	1	...	-1.15	-1.16
	count	11054.000000	11054.000000	...	11054.000000
		11054.000000			
	mean	0.313914	-0.633345	...	0.719739
					0.113986
	std	0.949495	0.765973	...	0.694276
					0.993527
	min	-1.000000	-1.000000	...	-1.000000
					-1.000000
	25%	-1.000000	-1.000000	...	1.000000
					-1.000000
	50%	1.000000	-1.000000	...	1.000000
					1.000000
	75%	1.000000	-1.000000	...	1.000000
					1.000000
	max	1.000000	1.000000	...	1.000000
					1.000000
3	3	1	...	1.8	1.9
	count	9999.000000	9999.000000	...	9999.000000
		9999.000000			
	mean	2.445045	0.586759	...	0.314031
					0.499950
	std	1.346892	0.751240	...	0.897862
					0.500025
	min	1.000000	0.000000	...	-1.000000
					0.000000
	25%	2.000000	0.000000	...	-1.000000
					0.000000
	50%	2.000000	1.000000	...	1.000000
					0.000000
	75%	3.000000	1.000000	...	1.000000
					1.000000
	max	21.000000	14.000000	...	1.000000
					1.000000

The summary statistics provides better insights about the three chosen datasets by exploring them.

### No of Selected Features

The filter-based feature selection algorithm chosen in this study is named ANOVA F-test. The features that recorded the highest scores were treated as the promising ones. In each of the datasets, the number of selected variables is as shown in table 3.

Table 3: No of selected features

S/N	Dataset Author and Year	Feature Selection Technique	No of Features Selected
1	Abdelhamid et al (2014) [14]	ANOVA F-score	3
2	Mohammad, McCluskey and Thabtah (2014) [15]	ANOVA F-score	9
3	Tan (2018) [16]	ANOVA F-score	22

### Results of Phishing classification using the selected algorithms

The performances of the three machine learning algorithms used in the study were validated using the three datasets described in table 1. For each of the experimentations, the datasets were split in the ratio 80:20 for the training and test sets respectively. Tables 4, 5, and 6 were used to present the performances based on the experimental analyses carried out.

Table 4: Classifier Performances using dataset by [14]

Algorithm	Dataset Used	Accuracy	Precision	Recall	F1-Score
Random Forest Classifier	Abdelhamid et al (2014) [14]	0.91	0.91	0.90	0.90
K-Nearest Neighbour Classifier	Abdelhamid et al (2014) [14]	0.89	0.89	0.89	0.88
ExtraTree Classifier	Abdelhamid et al (2014) [14]	0.90	0.89	0.90	0.89

Table 5: Classifier Performances using dataset by[15]

Algorithm	Dataset Used	Accuracy	Precision	Recall	F1-Score
Random Forest Classifier	Mohammad et al. (2014) [15]	1.00	0.99	0.99	0.99
K-Nearest Neighbour Classifier	Mohammad et al. (2014) [15]	0.92	0.92	0.92	0.92
ExtraTree Classifier	Mohammad et al. (2014) [15]	0.98	0.98	0.98	0.98

Table 6: Classifier Performances using dataset by [16]

Algorithm	Dataset Used	Accuracy	Precision	Recall	F1-Score
Random Forest Classifier	Tan (2018) [16]	0.99	0.97	0.98	0.97
K-Nearest Neighbour Classifier	Tan (2018) [16]	0.97	0.95	0.97	0.96
ExtraTree Classifier	Tan (2018) [16]	0.98	0.96	0.98	0.96

## V DISCUSSIONS

The results of the experimental analyses are discussed in this section. Exploratory Data Analysis was first of all carried out in all the three phishing datasets in order to understand the nature of the features in the datasets. This work pre-processed the phishing datasets with a view to making the features available in usable form for the learning algorithms. A filter-based attribute selection technique named ANOVA-F test was used. The chosen feature selection method selected promising features. Afterward, three machine learning based phishing detection models were built. From the experimental analyses, it is evident that Random Forest Classifier has the overall best performances across the four metrics. For instance, from the table 1, Random Forest Algorithm marginally performed better than the two other classifiers. Similarly, from table2, Random Forest algorithm performed better than the two algorithms while Extra Tree Classifier performed better than K-Nearest Neighbour. In table 3, the performances of the three classifiers are promising and Random Forest algorithm did well than the other two marginally under accuracy and f1-score as metrics. It was equally observed that the three algorithms averagely performed better when evaluated with the dataset released by [16] in all the four chosen metrics. Generally, all the machine learning algorithms performed excellently when compared to similar studies.

## VI CONCLUSION

This study investigated the performances of Random Forest, K-Nearest Neighbour and Extra Tree algorithms in three publicly available benchmark datasets. The three chosen datasets were pre-processed under the same conditions and were used to train and test the selected supervised learning algorithms. Accuracy, Precision, Recall and F1 score were used as metrics in the performance evaluation. The study reported that Random Forest algorithm has the most promising performances in all the metrics used for the evaluation. Similarly, experimental analyses showed that all the three algorithms have overall performances while using the phishing dataset released by Tan (2018). It is believed that the approach used in this work provided further insights into phishing detection research.

## VII ACKNOWLEDGMENT

We would like to thank all the anonymous reviewers who helped improved the original manuscript.

### VIII REFERENCES

- [1] APWG, “Phishing Activity Trends Report for Quarter four of 2020”, APWG Quarterly Report, retrieved from [https://docs.apwg.org/reports/apwg\\_trends\\_report\\_q1\\_2020.pdf](https://docs.apwg.org/reports/apwg_trends_report_q1_2020.pdf)
- [2] A. Pektaş & T. Acarman, “Botnet detection based on network flow summary and deep learning”. *International Journal of Network Management*, 28(6),2018 1–15. <https://doi.org/10.1002/nem.2039>
- [3] A. Chaudhary, A., S. Kolhe, S., & R. Kamal, R. (2016). An improved Random Forest Classifier for multi-class classification. *Information Processing in Agriculture*, 2016. <https://doi.org/10.1016/j.inpa.2016.08.002>
- [4] M. Zakariah, M., “ Classification of large datasets using Random Forest Algorithm in various applications : Survey”. *International Journal of Engineering and Innovative Technology (IJEIT)*, 4(3),2014, 189–198.
- [5] E. Bauer E. and R. Kohavi R., “An empirical comparison of voting classification algorithms: Bagging, boosting and variants”. *Machine Learning*, 36(1/2), 1999, 525–536
- [6] I. Breiman, L. ,”Stacked regressions. *Machine Learning*” 24(1),1996, 49–64.
- [7] Y. Freund, Y., & R. Schapire, R. (1996). Experiments with a new boosting algorithm. *In Proceedings of the Thirteenth International Conference on Machine Learning*,1996 148–156 Bari, Italy.
- [8] S. Patil, Y. Shetye, N.Shendage, “Detecting Phishing Websites Using Machine Learning”, *International Research Journal of Engineering and Technology (IRJET)*,2020,7(2)
- [9] V. Shahrivari. “Phishing Detection Using Machine Learning Techniques”, arXiv:2009.11116v1 [cs.CR], 2020
- [10] D. Jampen, G. Gür, T. Sutter, & B. Tellenbach . “Don ’ t click : towards an effective anti - phishing training . A comparative literature review”, *InHuman-centric Computing and Information Sciences*.<https://doi.org/10.1186/s13673-020-00237-7>, 2020
- [11] A. M. Oyelakin, O. M. Alimi, T. Abdulrauf “A Comparative Analysis of Machine Learning Algorithms for Detecting Phishing Urls”, *Journal of Computer Science and Control Systems, Oredia University, Romania*,2020, 13(2):16-19, available at <https://electroinf.uoradea.ro/index.php/jcscs/12-cercetare/reviste/jcscs/213-1st-issue-vol-13-nr-2.html>

- [12] A. Alswailem, B. Alabdullah ,N. Alrumayh, and A. Alsedrani, “Detecting phishing websites using machine learning,” In 2019 2nd International Conference on Computer Applications Information Security (ICCAIS),2019, 1–6
- [13] A. S. Manjeri, R. K., MNV, A., & Nair, P. C., “A Machine Learning Approach for Detecting Malicious Websites using URL Features”. *2019 3rd International Conference on Electronics, Communication and Aerospace Technology (ICECA)*,2019, 555–561. <https://doi.org/10.1109/iceca.2019.8821879>
- [15] R. Mohammad, T. L. McCluskey, and Thabtah, FadiAbdeljaber, “ Intelligent Rule based Phishing Websites Classification”. *IET Information Security*, 8 (3), 153-160. 2014, 1751-8709, available at <https://archive.ics.uci.edu/ml/machine-learning-databases/00327/>
- [14] N. Abdelhamid, A Ayesh and F. Thabtah “Phishing detection based Associative Classification data mining. *Expert Systems with Applications*”, 41 (13), 2014, 5948–5959, available at <https://archive.ics.uci.edu/ml/machine-learning-databases/00379/>
- [16] C. L. Tan, Choon Lin, “ Phishing Dataset for Machine Learning: Feature Evaluation, Mendeley Data, V1, 2018, doi: 10.17632/h3cgnj8hft.1, the dataset is available at <http://dx.doi.org/10.17632/h3cgnj8hft.1>
- [17] M. A. Hall, “Correlation-based Feature Selection for Machine Learning”, *a PhD Thesis at University of Waikato, 1999*

# AN OVERVIEW ON APPLICATION OF SIX SIGMA METHODOLOGY IN PLASTICS INJECTION MOLDING INDUSTRY

<sup>1</sup>Muhammad Iqbal Asif, <sup>2</sup>Tariq Khan, <sup>2</sup>M. N Babar

*Department of Mechanical, Mechatronics and Manufacturing Engineering  
(KSK Campus), University of Engineering and Technology Lahore, Pakistan.  
New Campus-KSK 54800, Pakistan;*

**Abstract-** In this research paper, the application of six sigma methodology in plastics injection moulding is reviewed. Every process in industry requires improvements to increase productivity and reduce defect rate and process variation. There are many process improvement techniques available to identify the root causes of defects and six-sigma is one of the most famous technique that is widely used to find the real defects causing factors by applying of different tools such as DMAIC. The DMAIC is acronym for Define, Measure, Analysis, Improve and Control method is used in implementing of six-sigma in manufacturing process to improve the quality level of moulded part. Plastics industries face many quality problems due to process variation that increase lead time, loss of money and non-smooth customer's relations. Many complaints are received from customer that the moulded parts have defects include surface marks, colour lines, hard fitting, air bubbles and flow marks. By using six-sigma technique, main aim is to find factors causing process variation and to identify which factors will resolve the problems in analysis phase. It was identified that by DMAIC, the defects rate can be reduced and process can be improved up to 50%. In the process of six-sigma, the statistical tools such as SIPOC, project charter, cause and effect diagram, brainstorming, Pareto chart, run chart and capability analysis are used to make sure that process is really improved. The sigma level has improved without any vast capital investment. Application of this methodology in manufacturing industries has given rise to a huge economic savings.

**Keywords:** DMAIC, Six sigma, Injection moulding, Plastics, Manufacturing industry.

## I. INTRODUCTION

### A. Historical back ground of Six-Sigma

In 1986, Six-sigma was presented by Bill Smith at Motorola as a statically founded way to minimize the defects rate in electronic manufacturing in Motorola Inc. in United State of America (USA). Later on, Allied signals and general electronics adopted this methodology, where it was initiated by Jack Welch [1], [2]. For the evaluation of six sigma, there were two significant contributions from general electronics (GE's) way of application. First, Jack Welch established great pattern of leadership. Second, he backed six-sigma up with a strong recompenses system.

General electronics altered its incentives compensation plans for the whole company so that 40% of the bonus based on six-sigma results and 60% on financials. This new scheme effectively attracted attentions of GE's employees to six-sigma. Furthermore, the training of six sigma has become requirement for development general electronics (GE's) business hierarchy. Jack Welch asserted that nobody well thought out for administration work without at least green belt training preparing before the end of 1998[3], [4][5]. Moreover, six-sigma has many improvements and changes the progression of time, also its application in manufacturing industries as well as services corporations. Six-sigma methodology is applicable in any fields includes products, school, business, transaction or process [6], [7][8]. It can also be applied in administration, business operation such as research and development, marketing, sales and other areas which directly effects the customer. It comprises on investigation of qualitative facts by using measurable techniques and tools [2], [9], [10]. The variation in manufacturing process can be reduced by six sigma methodology. Profits and advance improvement are connected with it. This methodology has taken consideration from practitioners and academics around the globe [2], [7], [11]. The process variation in moulding process causes defects in moulded parts such as surface marks, colour lines, black dots, flow marks and hard fitting that result of loss of money, lead time and non-smooth customer relation. The main objective of this study is to find out root causes of these defects and remove the defects to improve the quality of plastics product that save time money and time of manufacture.

### *B. Definition of Six sigma*

Six-sigma being systematic, well disciplined, organization wide strategic business, profit driven and customer concentric that assistances to emphasis on the emergent and bringing very close to perfect solution, service and product [5], [12], [13]. Six-sigma, in different ways, is used to reduce the variation in the process that to the quality problems or defects. Six-sigma is an initiative to increase productivity, enhance marketing part and recover customer's gratification with techniques and statistical tools that can chief to innovation significant in product quality. Six-sigma is a methodological and financial element that improve the process and product concurrently [7], [14], [15].

To become globally well matched and to attain business operational excellence industries are apply different quality improvement initiative like ISO certification, lean manufacturing, total quality management and quality circles etc. [16]– [18]. Nevertheless, the results by these wits are not much profitable and are time constrained. So, a methodology is required to be introduced and implemented which can provide significant improvement in short time. Six-sigma is that methodology that can offer significant improvement in short time. So, six-sigma is an important to discover its application for getting important gains and profit in term of quality, customer's satisfaction and market share [19]– [21]. [1], [12], [22], [23].

There are two approaches of six sigma methodology;

- I. DMAIC (D-define, M-measure, A-analysis, I-improve, C-control)
- II. DMADV (D-define, M-measure, A-analysis, D-design, V-verify)

DMAIC practice is applicable on current process or products that need be improved while the DMADV is applied on new process or product which are intended and applied in such a way that it can deliver a six-sigma recital

DMAIC Cycle

According to Deming cycle, the DMAIC method is based upon improvement process. It can be used in different area of enterprises or manufacturing industries.

The goal and requirements of this process are as following:

- It defines responsibilities and needs
- It defines organizational structure to gain the goal.
- Identify the settings and essential element to find estimated date of end of project.
- Gaining support from higher authority.

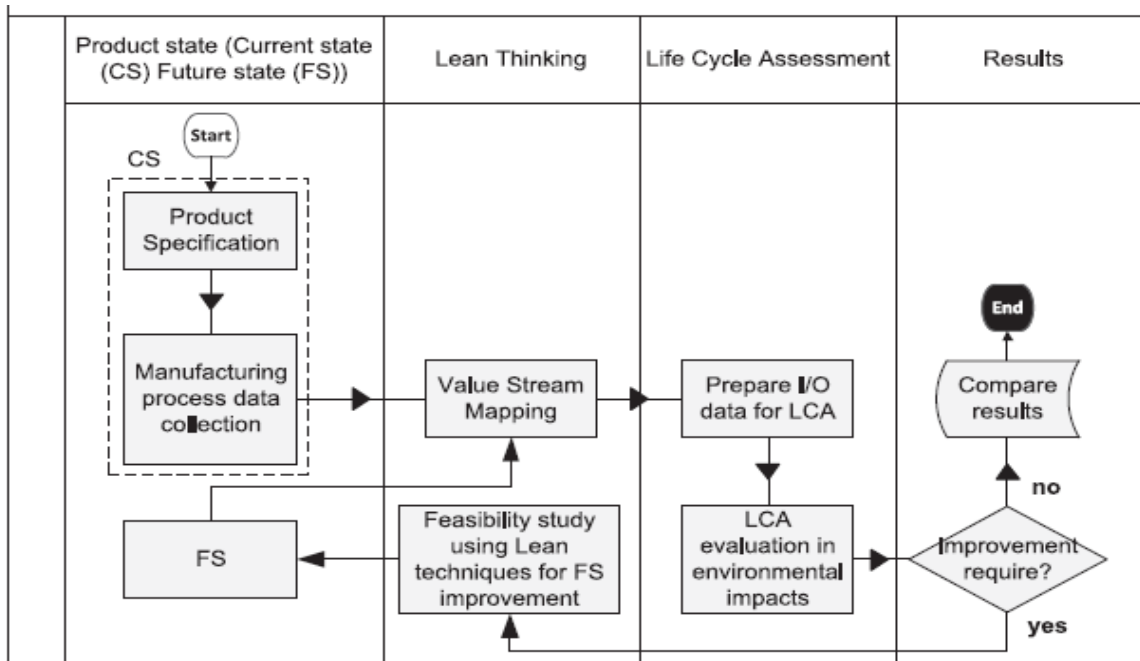

Figure 1 The map to proposed method of incorporating lean thinking in manufacturing environment[10].

The main purpose of this stage is to confirm the necessary actions to resolve the quality problems in manufacturing process. This method has different phases or steps through which a product or process can be improved.

This method starts by finding the problems that desire a solution and close with considerate these and clear indication of organisation management. An improvement has many ways to resolve a problem. It is necessary to focus on external factors that produce cost for association and remove the defects and then resolve internal problems of cost.

The following steps can be adopted to account the existing procedure:

- Identification of existing efficiency and performance.
- Examination if there are adequate facts to quantity
- Documentation of reliable and valid system of measurement

- Execution relative examinations.

C. *Six-Sigma methodology application in manufacturing industry*

Six-Sigma methodology is a statistical technique to investigation for excellence organisation. Hence, the DMAIC methodology is applied to improve the product quality in injection moulding process [11] [24]. Six-sigma has following phases in figure1;

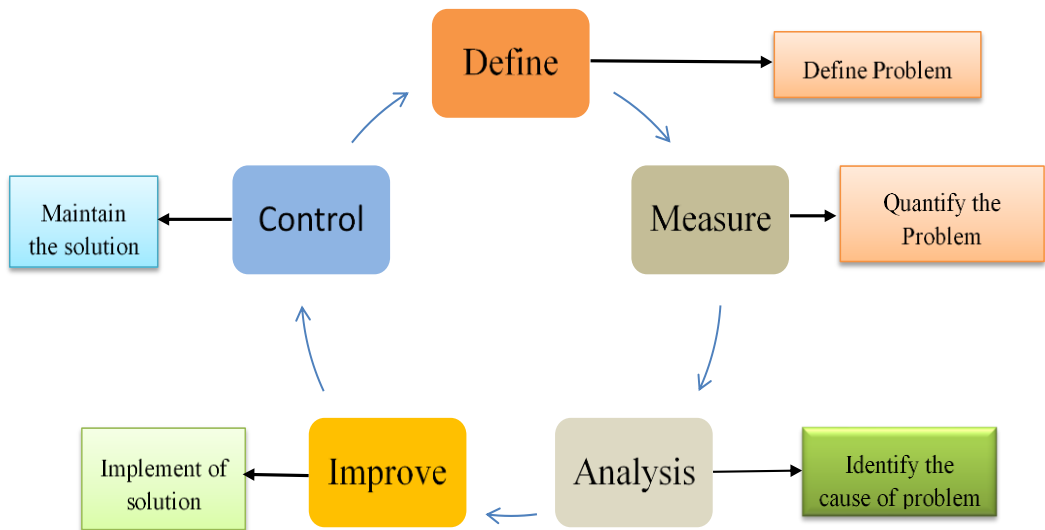

Figure 2 Six sigma methodology flow chart

A. Define Phase

The define phase is first phase of six-sigma methodology. In this phase project is selected, targets and initial goals are set. Moreover, the problem is also defined and grow a project statement or charter of exertion is being processed. The quality cost is calculated associated with existing process. Critical to quality (CTQ) and SIPOC (supplier, input, process, output, customer) analysis are recorded. Improvement goals and targets are set in term of cost associated and sigma level[25][3][26]. The define phase is also includes defining quality features and identification of root cause of defects.

In this phase project, problem and its objective are defined. Relevant statistical are also defined in this step that are used in this process improve the quality of process and find the root of defects or problems.

Supplier	Input	Process	Output	Customer
Polymer line Company	PVC pellets	↓	Fittings products	Thermosole Company
Interplast Company	Master batch		Runner + sprue	Al Ashrafiya Company
Al Watanis Company			Cycle information sheet	
Volta Dies and Mould Company	<ul style="list-style-type: none"> <li>• Melting temperature</li> <li>• Screw speed</li> <li>• Injection speed</li> <li>• Injection pressure</li> <li>• Packing pressure</li> <li>• Packing time</li> <li>• Mould time</li> <li>• Cooling time</li> </ul>			

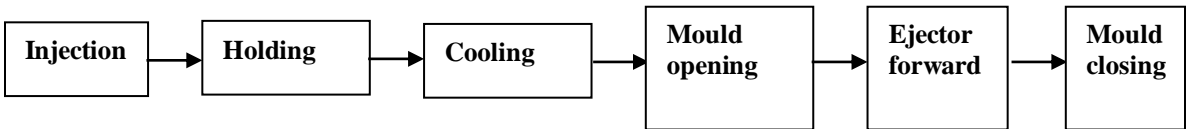

FIGURE 3 SIPOC DIAGRAM FOR INJECTION MOULDING PROCESS [11].

**A. Measure Phase**

The 2<sup>nd</sup> phase of six-sigma methodology is measure phase. Through this phase, observation as well as collection of data is approved and created on process capability analysis or DPMA (defect per million opportunity) is estimated on basis of the characteristics of data[13][9]

**B. Analysis phase**

*Analysis phase is third phase of this methodology. By this phase, possible reasons through which defects or variation are happening that are existing the process output is recognised. The very important stage in analysis phase is cause-and-affect diagram[28]. Six sigma researchers find possible causes which may create from material, source, machine, such as man, environment and methods. In this system, researchers adopt another technique called why-why analysis[21][15]. They find at least five possible reasons that have influence of specific causes, so that root cause of defects could be identified. Each suggestion may need clarification in order to make every participant know about effect of specific cause. Statistical tools and existing or new data is used to validate the causes such as analysis of*

variance(ANOVA), scatter plots, regression, design of experiment (DOE) and hypothesis testing. Implementation of wastage of resources and ineffective improvement can be prevented by validating the root causes[18][29][30].

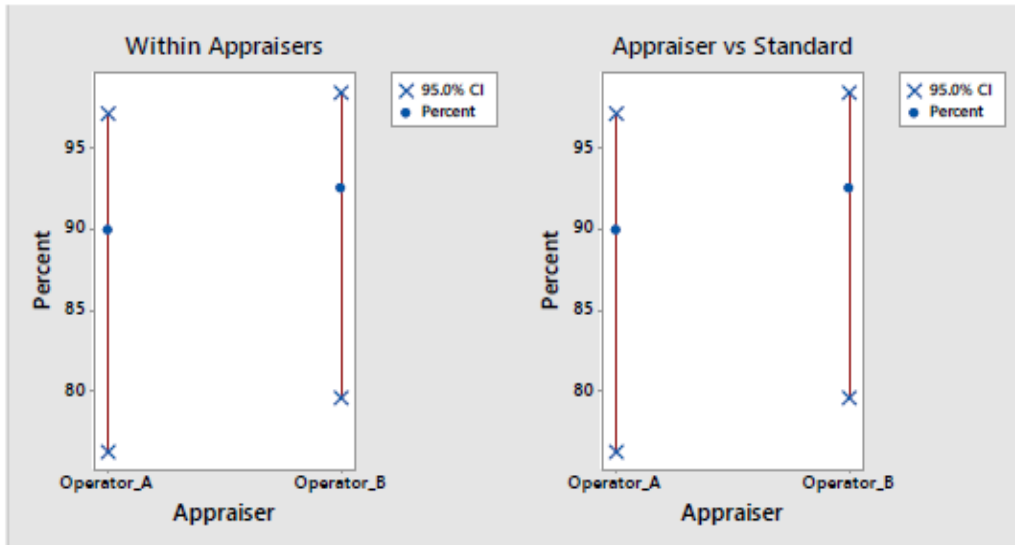

Figure 4 Characteristic arrangement analysis [11]

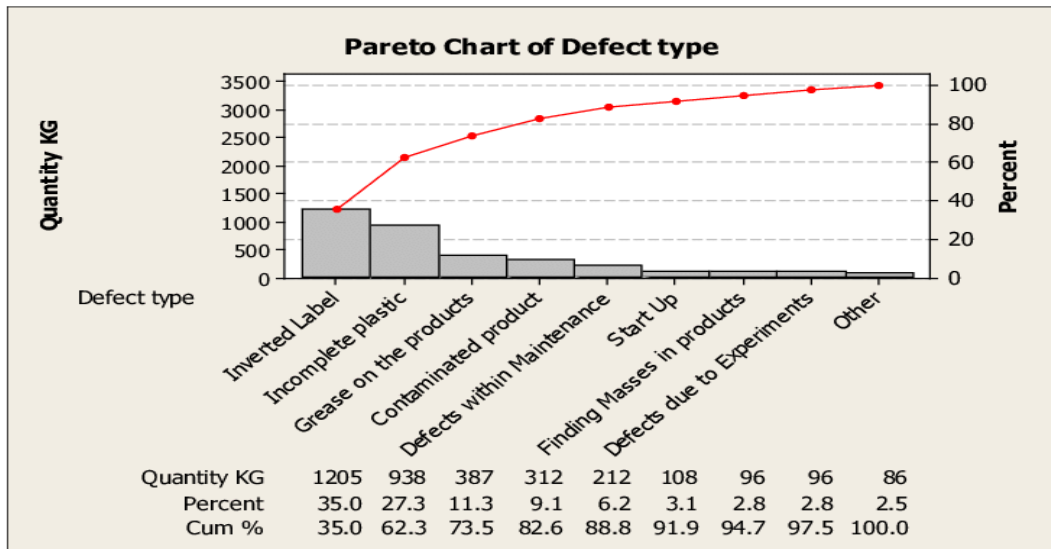

Figure 3 Pareto chart of the types of defects and defectives [2]

## B. Improve Phase

The improve phase is forth phase of six sigma methodology. After analysis of collected data, the defects or variation is reduced that is critical for customer satisfaction. To reduce the defect rate, countermeasures are recorded that could be applied to improve the process in this phase. Ideas and solutions of issues are presented by using affinity diagram[24]. On the bases of probability of success, the list should be lessened to one or two potential improvements, time execution, cost and impact on resources[31][27]. On the basis of solutions and ideas, a pilot project is carried out for the application and data collection is carried out. The researcher team should continue full scale implementation, if small scale implementation offers severe success[2][13][19].

In order to attain improvement, it was proposed to:

- Collect tools and parts at spot
- Remove interior operations
- Simplify set-up to decrease alterations
- Replace only essential fragments and make all others as world-wide as possible
- measure time.

*It was suggested to develop and complete the external set-up checklist to define the needed tools, materials and gauges and their storage location.*

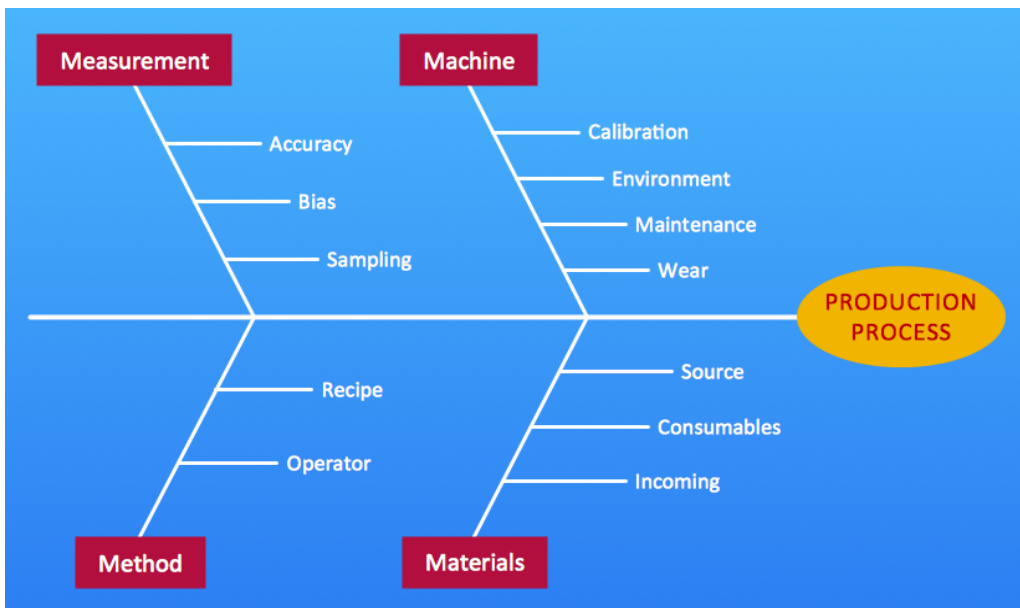

FIGURE 6 FISHBONE DIAGRAM

In figure 6, fishbone or Ishikawa diagram is shown. This diagram is used to find out the actual defects or problems in process. Different sections that are related to the process are included in fishbone diagram to analysis the root cause of defects in any process. This diagram is not specifying any process, rather than, it can be used in any operation, process, transaction that need to improve their quality. In this diagram,

main components of operations and their relevant equipment are included so that actual process to be analysed. Every process and its involved equipment like machine or its parts, material and operator are considered. This diagram is constructed over that sections that involve in this whole process. For example, un-trained machine operator could not handle the machine and moulded product properly to avoid from problems. In this way, delay in maintenance or improper maintenance is also a major factor that causes the defects. Improper maintenance of machine may causes leakage of oil, burning of material and flow marks in moulded parts. Environment is also having big contribution in defect rate and process variation such as moisture, overheating and dust particles which cause contamination in material.

The measurements in process are also having major role in process variation. Inspection and testing of material and its moulded parts require special care. Negligence and inappropriate techniques affect the quality of products. The measurements require accuracy during process running. The incoming material refers to raw material that received from client for manufacturing. Contamination in material or mixing of different materials leads to colour lines, burn marks and spots on the surface. The manufacturing of material and its delivery is referred to material source also accounted for improvement of quality of moulded parts.

		Importance to customer (1-10)	6	3	5	10				
		Output Variables (Ys) →	Weight	Cycle Time	Thickness	Number of Defects				
Process step	Input Variables (Xs) ↓	Weighted score (X)					%	Order	Status (Critical or Eliminated)	
Injection Molding Process	Injection Speed	9	9	9	9	216	23.7	1	critical	
	Injection Pressure	9	3	9	9	198	21.7	3	critical	
	screw Speed	3	9	3	3	90	9.9	4	eliminated	
	Packing Pressure	3	1	1	3	56	6.1	6	eliminated	
	Packing Time	3	3	1	1	42	4.6	7	eliminated	
	Cooling Time	3	3	1	3	62	6.8	5	critical	
	Meting Temperature	9	9	9	9	216	23.7	2	eliminated	
	Clamping Force	0	1	0	0	3	0.3	9	eliminated	
	Contamination of Material	0	0	0	3	30	3.3	8	eliminated	
<b>Weighted Score (Y)</b>		<b>39</b>	<b>38</b>	<b>33</b>	<b>40</b>	<b>913</b>				

Figure 4 cause and effect matrix[11]

**Sigma level can be computed by using following formula**

$$\begin{aligned}
 \text{Over-all rejection} &= R \\
 \text{Total mass-produced parts} &= P \\
 \text{Total CTQ} &= O \\
 \text{Defect per unit (DPU)} &= R/P \\
 \text{DPO} &= \text{DPU}/\text{CTQ} \\
 \text{DPMO} &= \text{DPO} \times 106 \\
 \text{Sigma level} &= 0.8406 + \sqrt{\{29.37 - 2.221 \ln(\text{DPMO})\}}
 \end{aligned}$$

A. Control Phase

The last and fifth phase of six sigma methodology is control phase. Control of improved implementation is done in this phase. Indication should be displayed by early signal, if process is going towards out of control[14][32]. Team may develop devices which use lights, no go designs, logic program, sound, indicators to control a process[33]–[35]. The main purpose of this step is to control the inputs and monitoring the outputs to reduce the variation. The actual encounter of six sigma application is not in making improvement in the operations but supporting attained results[21], [22][36].

Figure 3 shows major steps which are taken during in manufacturing process. This chart also explains SIPOC (Supplier, Inputs, Process, Output and Customer).

This chart relates the whole cycles starting from supplier to customer voice. In this, all process and critical inputs and output as well as customer requirement are considered. This chart also explains how and when a process can be started.

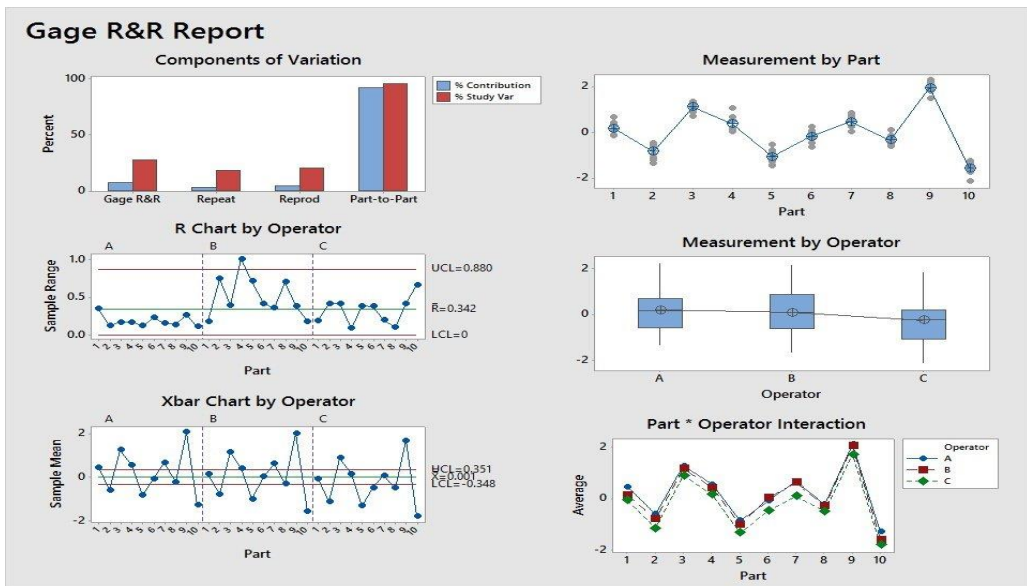

Figure 8 Gage R & R (Repeatability and Reproducibility) [37]

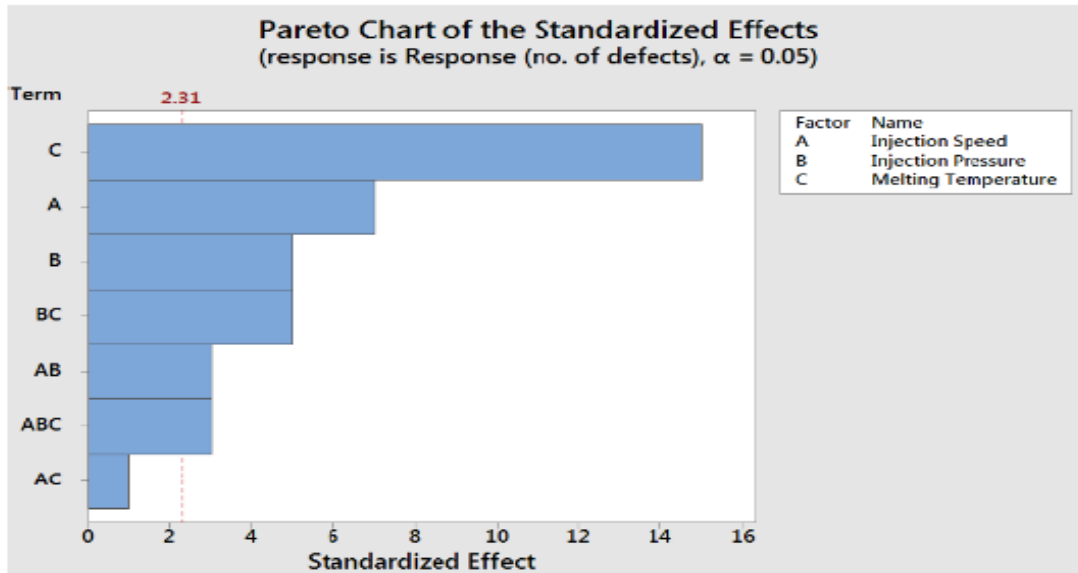
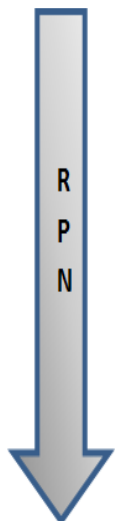

Figure 9 Pareto chart for the standardized effects [11]



RPN	Failure mode	Action Plan
560	Dryness of material	✓ Use a drying machine
294	Contamination of material	✓ Reduce the recycled material and distribute it evenly among the batches of PVC
270	Occupational health issues	✓ Provide a first aid kit ✓ Provide frequent breaks
160	Behavior of operator	✓ Assign rewarding and recognition programs ✓ Assign penalties
140	Cleanness of mold	✓ Make a schedule to clean the mold
84	Insufficient amount of material inserted	✓ Make a schedule to check the amount of material in the hopper

FIGURE 10 ACTION PLAN FOR MANUFACTURING PROCESS

A short tool kit and six sigma improvements are shown in below table 1[38] [39]:

Table 1 Six sigma improvements and statistical tools

Define Phase	Measure Phase	Analysis Phase	Improve Phase	Control Phase
Customer needs	=====	Control charts	=====	Preventive activity
Benchmark	Seven Q.C tools	Cause & Effect diagram	Design of Experiment (DOE)	Control charts
Charter	Data collection forms, plan, logistics	Decision & risk analysis	Tolerancing	Procedural adherence
Quality function deployment	=====	Capability	=====	=====
Kano model	Sampling techniques	Statistical inference	Robust design	Performance management
Baseline	Defect metrics	(FMEA)	Modelling	Time series methods
Process flow map	=====	Reliability analysis	=====	=====
Management by fact	=====	Systems thinking	=====	=====
Project management	=====	Root cause analysis	=====	=====

## VI. CONCLUSION AND FUTURE RESEARCH DIRECTION

The implementation of six-sigma in injection moulding industry brought a significant improvement in quality of moulded parts. Six-sigma DMAIC is an easy way to find root cause of defects that responsible for process and remove them. This technique really helped to reduce variation up to 50% in injection process. Real causing factor is found in analyze phase that made it clear that the root causes of process variation is due to un-trained machine operator, material handling and improper maintenance of machine. In improvement phase, the process improved by applying statistical tools in six-sigma DMAIC methodology. Maintenance check sheet has been made and handed to industry management to maintain process improvement. Six-sigma does not

depend upon material. It is just process improvement technique to improve the quality of process and remove the process variations. Moreover, Six-sigma can applicable due remarkable improvements in different fields or sector that want to improve their work or business and operating excellence. Through six sigma methodology, productivity, profitability and quantum attain in quality can be achieved.

Some Recommendations for change of material from plastics to rubber

- Rubber material requires more pressure as compared to plastics material per square inch of cavity surface in moulding. So, high injection pressure machine is required.
- The cavity of mould for rubber is different from plastics mould that requires more cooling time for solidifies of material. Conformal cooling channel are required is mould cooling.

Avoid from regrinding material or recycled material put into resin for rubber manufacturing.

#### ACKNOWLEDGMENT

This paper is published by students of University of Engineering and Technology, Lahore Pakistan. This an overview of six sigma to improve the quality of plastics products in injection moulding industry.

#### REFERENCES

- [1] W. Timans, K. Ahaus, and J. Antony, "Six sigma methods applied in an injection moulding company," *Int. J. Lean Six Sigma*, vol. 5, no. 2, pp. 149–167, 2014, doi: 10.1108/IJLSS-07-2013-0037.
- [2] P. Bharara, "Implementation of DMAIC Methodology for reduction of weighted-defects in a vehicle assembly process," *Int. J. Appl. Eng. Res.*, vol. 13, no. 6, pp. 73–80, 2018, [Online]. Available: <http://www.ripublication.com>.
- [3] Y. Zheng, F. Gu, Y. Ren, P. Hall, and N. J. Miles, "Improving Mechanical Properties of Recycled Polypropylene-based Composites Using TAGuchi and ANOVA Techniques," *Procedia CIRP*, vol. 61, pp. 287–292, 2017, doi: 10.1016/j.procir.2016.11.137.
- [4] M. V Kavade, "Parameter Optimization of Injection Molding of Polypropylene by using Taguchi Methodology," *IOSR J. Mech. Civ. Eng.*, vol. 4, no. 4, pp. 49–58, 2012, doi: 10.9790/1684-0444958.
- [5] M. Smętkowska and B. Mrugalska, "Using Six Sigma DMAIC to Improve the Quality of the Production Process: A Case Study," *Procedia - Soc. Behav. Sci.*, vol. 238, pp. 590–596, 2018, doi: 10.1016/j.sbspro.2018.04.039.
- [6] N. M. Mehat and S. Kamaruddin, "Optimization of mechanical properties of recycled plastic products via optimal processing parameters using the Taguchi method," *J. Mater. Process. Technol.*, vol. 211, no. 12, pp. 1989–1994, 2011, doi: 10.1016/j.jmatprotec.2011.06.014.
- [7] M. T. Scholar and P. Haryana, "Improvement in Production Rate By Reducing the Defects of Injection Moulding," vol. 4, no. 3, pp. 1–4, 2012.
- [8] S. Lampreia, V. Vairinhos, and V. Lobo, "the Problematic of Condition Based Maintenance," no. November, pp. 665–668, 2018.
- [9] T. Lin and B. Chananda, "Quality Improvement of an Injection-Molded Product Using Design of Experiments: A Case Study," *Qual. Eng.*, vol. 16, no. 1, pp. 99–104, 2003, doi: 10.1081/QEN-120020776.
- [10] W. M. Cheung, J. T. Leong, and P. Vichare, "Incorporating lean thinking and life cycle assessment to reduce environmental impacts of plastic injection moulded products," *J. Clean. Prod.*, vol. 167, pp. 759–775, 2017, doi: 10.1016/j.jclepro.2017.08.208.

- [11] A. Alshammari, S. Redha, S. Hussain, T. Nazzal, Z. Kamal, and W. Smew, "Quality improvement in plastic injection molding industry: Applying Lean Six Sigma to SME in Kuwait," *Proc. Int. Conf. Ind. Eng. Oper. Manag.*, vol. 2018-March, pp. 2856–2865, 2018.
- [12] V. Dwivedi, M. Anas, and M. Siraj, "Six Sigma ; As Applied in Quality Improvement for Injection Moulding Process," vol. 4, no. 4, pp. 317–324, 2014.
- [13] R. Nurcahyo, L. Rini, and D. P. Ishak, "Qualtiy improvement in plastic based toy manufacturer using six sigma method," *Proc. Int. Conf. Ind. Eng. Oper. Manag.*, vol. 8-10 March, no. November, pp. 2634–2643, 2016.
- [14] B. Ozcelik, "Optimization of injection parameters for mechanical properties of specimens with weld line of polypropylene using Taguchi method," *Int. Commun. Heat Mass Transf.*, vol. 38, no. 8, pp. 1067–1072, 2011, doi: 10.1016/j.icheatmasstransfer.2011.04.025.
- [15] M. Zhai and Y. Xie, "A study of gate location optimization of plastic injection molding using sequential linear programming," *Int. J. Adv. Manuf. Technol.*, vol. 49, no. 1–4, pp. 97–103, 2010, doi: 10.1007/s00170-009-2376-1.
- [16] J. K. Kim and E. S. Jeon, "Optimization of injection molding process parameters to improve mechanical strength of LFT specimen," *Int. J. Appl. Eng. Res.*, vol. 12, no. 13, pp. 3671–3676, 2017.
- [17] S. Zabihi, F. Zare, G. Ledwich, and Z. Zabihi, "±%ç| Ätä TM Á ? ±%ç| Ätä TM Á ? ±%ç| Ätä TM Á ? E2 ±%ç| Ätä TM Á ? ±%ç| Ätä TM Á ? ±%ç| Ätä TM Á ? E2," no. 54, p. 24, 2014.
- [18] H. S. Park, D. X. Phuong, and S. Kumar, "AI based injection molding process for consistent product quality," *Procedia Manuf.*, vol. 28, pp. 102–106, 2019, doi: 10.1016/j.promfg.2018.12.017.
- [19] L. M. Galantucci and R. Spina, "Evaluation of filling conditions of injection moulding by integrating numerical simulations and experimental tests," *J. Mater. Process. Technol.*, vol. 141, no. 2, pp. 266–275, 2003, doi: 10.1016/S0924-0136(03)00276-0.
- [20] R. Zuraimi, M. A. Sulaiman, E. Mohamad, and J. A. Ghani, "Tensile strength analysis of high density polyethylene for injection moulded parts," *J. Adv. Manuf. Technol.*, vol. 11, no. 1 Special Issue, pp. 151–164, 2017.
- [21] A. Mansur, Mu'Alim, and Sunaryo, "Plastic Injection Quality Controlling Using the Lean Six Sigma and FMEA Method," *IOP Conf. Ser. Mater. Sci. Eng.*, vol. 105, no. 1, 2016, doi: 10.1088/1757-899X/105/1/012006.
- [22] N. Bakshi, "Quality Improvement of Plastic Timer-A Six," vol. 4, no. Xii, pp. 612–618, 2016.
- [23] A. Mishra, P. Mishra, and Sachendra, "Six Sigma Methodology In A Plastic Injection Molding Industry: A Case Study," *Int. J. Ind. Eng. Technol.*, vol. 7, no. 1, pp. 974–3146, 2015, [Online]. Available: <http://www.irphouse.com>.
- [24] M. Zasadzien, "Application of the six sigma method for improving maintenance processes – case study," *ICORES 2017 - Proc. 6th Int. Conf. Oper. Res. Enterp. Syst.*, vol. 2017-Janua, no. Icores, pp. 314–320, 2017, doi: 10.5220/0006184703140320.
- [25] N. Patel and S. Shah, "A Review on Implementation of Six Sigma in Manufacturing Industries," *J. Emerg. Technol. Innov. Res.*, vol. 2, no. 2, pp. 368–371, 2015, [Online]. Available: <http://www.jetir.org/papers/JETIR1502035.pdf>.
- [26] K. Antosz and D. Stadnicka, Possibilities of maintenance service process analyses and improvement through six sigma, lean and industry 4.0 implementation, vol. 540. Springer International Publishing, 2018.

- [27] N. V. Fursule, S. V. Bansod, and S. N. Fursule, "Understanding the Benefits and Limitations of Six Sigma Methodology," *Int. J. Sci. Res. Publ.*, vol. 2, no. 1, pp. 2250–3153, 2012, [Online]. Available: [www.ijsrp.org](http://www.ijsrp.org).
- [28] B. Ankenman, "Design of Experiments with Two-Level and Four-Level Factors by," pp. 1–17, 1999.
- [29] A. A. S. Mariam Atiqah, H. Salmah, Z. Firuz, and D. N. U. Lan, "The effect of blend ratio on properties of Recycled Polypropylene/Recycled High Density Polyethylene geo-composites," *Malaysian J. Anal. Sci.*, vol. 18, no. 2, pp. 344–350, 2014.
- [30] J. N. Hahladakis and E. Iacovidou, "Closing the loop on plastic packaging materials: What is quality and how does it affect their circularity?," *Sci. Total Environ.*, vol. 630, pp. 1394–1400, 2018, doi: 10.1016/j.scitotenv.2018.02.330.
- [31] R. Fitriana, J. Saragih, and D. P. Larasati, "Production quality improvement of Yamalube Bottle with Six Sigma, FMEA, and Data Mining in PT. B," *IOP Conf. Ser. Mater. Sci. Eng.*, vol. 847, no. 1, 2020, doi: 10.1088/1757-899X/847/1/012011.
- [32] I. Meekers, P. Refalo, and A. Rochman, "Analysis of Process Parameters affecting Energy Consumption in Plastic Injection Moulding," *Procedia CIRP*, vol. 69, no. May, pp. 342–347, 2018, doi: 10.1016/j.procir.2017.11.042.
- [33] A. S. KHULLI, P. SHIRODKAR, and K. N. VIJAYA KUMAR, "Implementation of Six Sigma Process in Identifying and Analysis Error in Piping Isometric Drawings ," *Int. J. Prod. Technol. Manag.*, vol. 10, no. 1, pp. 60–67, 2019, doi: 10.34218/ijptm.10.1.2019.006.
- [34] A. Ishak, K. Siregar, Asfiryati, and H. Naibaho, "Quality Control with Six Sigma DMAIC and Grey Failure Mode Effect Anaysis (FMEA): A Review," *IOP Conf. Ser. Mater. Sci. Eng.*, vol. 505, no. 1, pp. 0–8, 2019, doi: 10.1088/1757-899X/505/1/012057.
- [35] A. Sujova, L. Simanova, and K. Marcinekova, "Sustainable process performance by application of Six Sigma concepts: The research study of two industrial cases," *Sustain.*, vol. 8, no. 3, 2016, doi: 10.3390/su8030260.
- [36] N. Pirc et al., "Cooling channel optimization for injection molding To cite this version: HAL Id : hal-01354303 Cooling channel optimization for injection molding," 2019.
- [37] P. Rumana and D. A. Desai, "Review Paper: Quality Improvement through Six Sigma DMAIC Methodology," *Int. J. Eng. Sci. Res. Technol.*, vol. 3, no. 12, pp. 169–175, 2014, doi: 10.15680/IJRSET.2016.0512037.
- [38] M. N. BIN ROHAIZAT, "Shrinkage Based on Plastic Flow Simulation Software : Hand," no. December, p. 24, 2010.
- [39] J. M. Faiz, Z. Shayfull, S. M. Nasir, M. Fathullah, and M. H. M. Hazwan, "Optimisation of process parameters on thin shell part using response surface methodology (RSM) and genetic algorithm (GA)," *AIP Conf. Proc.*, vol. 1885, no. October, 2017, doi: 10.1063/1.5002280.

# Madadgar(Anti theft-SOS) Android App

<sup>1</sup>Amna Waqar, <sup>1</sup>Syeda Khadijia Hamid <sup>1,2</sup>Mohammad Ayoub Kamal

<sup>1</sup>. College of Computer Science & Information(CCSIS),Institute of Business Mangement(IoBM),  
Karachi,Pakistan

<sup>2</sup> Malaysian Institute of Information Technology,Universiti Kuala Lumpur(UniKL MIIT),  
Kuala Lumpur,Malaysia

Keywords: Android, Anti-theft, Crime, Snatching, Kidnapping, SOS button, Lodge complain.

**Abstract-**This paper presents an anti-theft application for android based devices to find stolen or lost vehicles, child, and report of crime, mobile snatching, lost of person, vehicle verification and Emergency SOS button. As we all know after mobile snatching people faced a lot of difficulty in Blocking of sim, and lodging mobile theft complains, but with this app user will be able to lodge complains in just few minutes and the client will moreover be able to call for offer assistance in case of crisis by squeezing SOS button at which exact location of the user will send to response center without consuming time.Now this application work as once this application installed in user's android mobile device,it will stored user's email id,mobile phone number,and CNIC number ,collect the data from the sensors and keep running in the background by using services.Example:1 If the user is in emergency situation he/she just trigger the SOS button for help then location of the victim will go to response center and they will trace the location and take immediate action .Example :2 If user see any robbery nearby his area he can easily make video and take pictures of that incident then simply upload it in this application through form filling.Example:3 If user's vehicle or child is lost then he can upload vehicle or child pictures with detailed information by filling form.The purpose of this application is to bring Citizens of Pakistan and CPLC on one platform .This app will end the hassle to visit or call police station/CPLC and will allow the user to lodge complains, call for help through user friendly forms instantly. This collaboration will allow Citizens of Pakistan and security forces to associate with each other more efficiently. It will become an important part of people's everyday lives as it combines simplicity and usefulness and brings Pakistani Forces and citizens on one single platform.

## I- Introduction

MADADGAR is a mobile app for citizens of Pakistan. It is a project in collaboration with CPLC which stands for Citizens-Police Liaison Committee ,which is a nonprofit government agency for public security. The purpose is to bring Citizens of Pakistan and CPLC on one platform. This app end the hassle to visit or call police station/CPLC and will allow the user to lodge complains, call for help through user friendly forms immediately.

The Citizens-Police Liaison Committee, or CPLC, was established by Fakhruddin Ibrahim [1]. It is a non-political constitutional entity that is autonomous while maintained via committed citizens who volunteer. CPLC is a one-of-a-kind public-private collaboration in which citizens volunteered and helped.CPLC is a one-of-a-kind public-private partnership in which citizens stepped forward as volunteers, assumed responsibility for improving the deteriorating law and order situation in collaboration with law enforcement agencies, and worked tirelessly to achieve its noble goals.

Its services include

---

<sup>1</sup>Std\_24575@iobm.edu.pk <sup>2</sup>Std\_22376@iobm.edu.pk



**Figure-1**

- Report of mobile theft
- Report of child lost
- Report of vehicle robbery
- Sim blocking
- Verify while buying a car or bike



Citizens Police  
Liaison Committee

**Figure-2**

## II- Background

The latest android based mobile phones has become a very important part of our life[2]. It provides helps in communicating with anyone virtually through videoconferencing, email, etc or GPS. But with technological advancement the users have started to use android phones for storing private and confidential information like atm pin, video ,documents etc[3]. This factor has increase the mobile snatching across Pakistan. The Karachi is the biggest populated city of Pakistan[4]. The crime rate is very high in Karachi especially mobile snatching. The Fig (1)[1] shows the crime rate of mobile theft in Karachi published by CPLC.



Not only mobile snatching is a problem of Karachi but other crimes have also increased. According to CPLC ,in year 2020 Karachi witnessed a rise in car lifting, snatching of motorbikes and mobile phones and theft of two-wheelers compared to 2019 as shown in table (2).

Type	2019	2020
<b>Car stolen</b>	1452	1527
<b>Mobile Snatched</b>	19,862	21,578
<b>Motorbikes Stolen</b>	28,609	34908

Table(1)

The fig (3) shows the vehicle snatching rate per hour in Karachi. Once the phone or vehicle is snatched, users may face a severe risk of loss of privacy, may not only cause loss of property but also have a negative impact on the their family life. However Now a days people find it really difficult to report these increasing due to visiting police station for reporting crime takes a lot of time and specially for females it is very difficult to go to police station for reporting so by using. In order to solve these problem this paper proposed an android app called “MADADGAR”

MADADGAR is a mobile app for citizens of Pakistan. It will be a project in collaboration with CPLC. The Citizens-Police Liaison Committee commonly known as CPLC, is a nonprofit government agency for public security [6]. The purpose is to bring Citizens of Pakistan and CPLC on one platform. This app will end the hassle to visit or call police station/CPLC and will allow the user to lodge complains call for help through user friendly forms immediately.

### III- Literature Review

**(1)User Login:** The application ask user to login/register when the app is first time initialized. It will protect user’s identification and data[5]. Then user uses application properly. User registration form honestly saves data of user and reduces risk of security[6]. **SOS Button:** When user is in emergency, they can trigger the SOS button display on the interface, or widget to instant request for help in fastest and convenient way[7]. This emergency function will send victim’s current location to control tower of organization[8]. **Lodge complain:** User can make video or picture of any snatching ,kidnapping or robbery etc[9]. and upload in this application through form filling. After this user’s location will trace by organization in a very short time .User can lodge any kind of complain like mobile, child or vehicle etc. lost by just filling form. Following table shows the brief literature review of different applications which are similar to Madadgar application but they have lack in features:

Paper name	Author name	Problem address	Limitation
Anti-Theft Application for android based devices [2]	Azeem Ush shan Khan, Mohammad Naved Quershi, Mohammad Abdul Qadeer	This paper puts a technique through which the thief, who steal mobile phone with application ,get captured and user can stop him for misusing.	This application is only for mobile stealing.

ThiefTrap – An Anti-theft Framework for Android[10]	Sascha Groß, Abhishek Tiwari, and Christian Hammer	This ThiefTrap, using a honeypot account for the purpose of theft protection.	It has only a feature for mobile stealing.
Android Based Emergency Alert Button[11]	Dhrubajyoti Gogoi, Rupam Kumar Sharma	<i>This application is used for immense help by SOS button.</i>	The location of user will go to family not to center.
Design and implementation of anti- theft tracking system based on Android platform[12]	Yonghong Luo, Jian Wang, and Chao Feng	Android handset anti-theft tracking system which would automatically destroy private information and track cellphone location to protect user privacy and property security after the phone lost.	This application is only for mobile lost.
Position Detection and Tracking System[13]	Mahesh Kadibagil, Dr. H S Guruprasad	Application used to find location and send a Popup SMS to user when his/her friends or family members come around the user's area of direction.	In this android application location of the user will go to his family members not to organization.
A Low-Cost Vehicle Anti-Theft System Using Obsolete Smartphone[14]	Bang Liu, Nianbo Liu, Guihai Chen, Xili Dai, and Ming Liu	After being fixed in vehicle body, the smartphone can detect vehicle movement and adaptively use GPS.	This application is for vehicle tracking.
Anti -Theft Application for Lost or Misplaced Android Phones[3]	Sayali Deore, Karishma Khodade, Shweta Patil	This application provide the user to track their lost or misplace device.	This application only trace the lost android mobile device.

**Table(2): (Brief literature review of Madadgar app to other similar application**

## IV- Methodology

The major tools that were used to develop and their description are provided below.

### A) Software development tools:

**Android studio:** The most well-known IDE (integrated development environment) for developing Android apps is Android Studio[15]. It enables developers to design apps from the ground up. It may run on a variety of operating systems, including Windows, macOS and Linux based operating systems or as a subscription-based service in 2020 [15]. The minimum requirements are: 1) 2 GB RAM minimum, 4 GB RAM recommended. 2) 400 MB hard disk space. 3) Java Development Kit (JDK) 7.4) 64-bit processor.

Activities and Services in android:

In this application we use activities to draw the user interface, which collects all the user related information like mobile number, email id, password, etc which will be used to send videos or pictures. Services are used to run the application in the background that is without user interaction, once a user submits all the related information, services get started in the background[16].

**Activity :** An activity is a component of an application which gives an interface to the user to communicate with the application like taking pictures, submitting forms and making videos. Android gives a screen to each activity to draw the GUI. Android uses stack to manage the activities, when an activity is created it is placed on the top of the stack and the previous activities remain below it. Internet is very important in this case because we need to track location and we can find location of crime reporter because internet is connected with multiple routers through routing protocols[17].

**Services :** A service is a component of an application which performs an operation in the background without user interaction, it does not have any user interaction so it is not included in activity life cycle. A service can be started by any other component of an application by creating intent or it can be started by its own. Once a service is begun, user can switch to another application, It will remain running continuously.

**Firestore:** Firestore is a Google platform that makes it simple for developers to create, manage, and scale their projects. It enables developers to create apps more quickly and securely[18]. On the Firestore side, no programming is necessary, making it simple to take advantage of its features. It works with Android, iOS, the web, and Unity. It gives you access to cloud storage[19]. It makes advantage of NoSQL for the database. **Realtime Database:** The Firestore Realtime Database is a cloud-based NoSQL database that allows you to manage your data in milliseconds. In the simplest terms, it can be thought of as a large JSON file. It's the database that allows you to store and sync data in real time between your users. Real-time syncing allows your users to view their data from any device, including the web and mobile, and it allows them to collaborate. Real-time Database comes with mobile and web SDKs, allowing you to create apps without using servers. The Real-time Database interfaces with Firestore Authentication to give developers a quick and straightforward way to log in. Our declarative security paradigm can be used to provide access based on user identity or data pattern matching[20].

**Java:** Java is the innovation of choice for building applications utilizing overseen code that can execute on mobile devices. A Java coordinates improvement environment for computer program, and consolidates its

code altering and developer tools. To support application advancement inside the Android operating system.

## B) Requirements Analysis

### Domain Requirements

The projects aim to build a mobile app. It will be connected with Firebase realtime database. There are 2 major functioning parts to this project functional requirement and non-functional requirement[21]. Firstly user friendly forms for data entry that will be design on the Android studio. Android Studio is the official Integrated Development Environment (IDE) for Android app development, based on IntelliJ IDEA . It allow you to use Code templates and GitHub integration to help you build common app features and import sample code. Secondly Firebase realtime database which is the main part of the app. It will be to collect and save information submitted by user. For tracing the exact location Google API will be used in the backend of SOS button.

#### ● Functional Requirements

- User friendly form will develop separately for each service the app offer.
- User registration and its authentication will be a must to use app
- The elements and formats should be defined for each field in form as it is necessary for storing data in correct format in database
- User must allow the app to track its location
- The mobile data or wifi should be on before using the app.

#### ● Non-Functional Requirements

- The app will be highly mobile friendly.
- User can use app from any part of the world
- Small popup message on top of screen when user is offline.
- Login to app through GMAIL or mobile number
- Registration through personal email (requiring email verification)

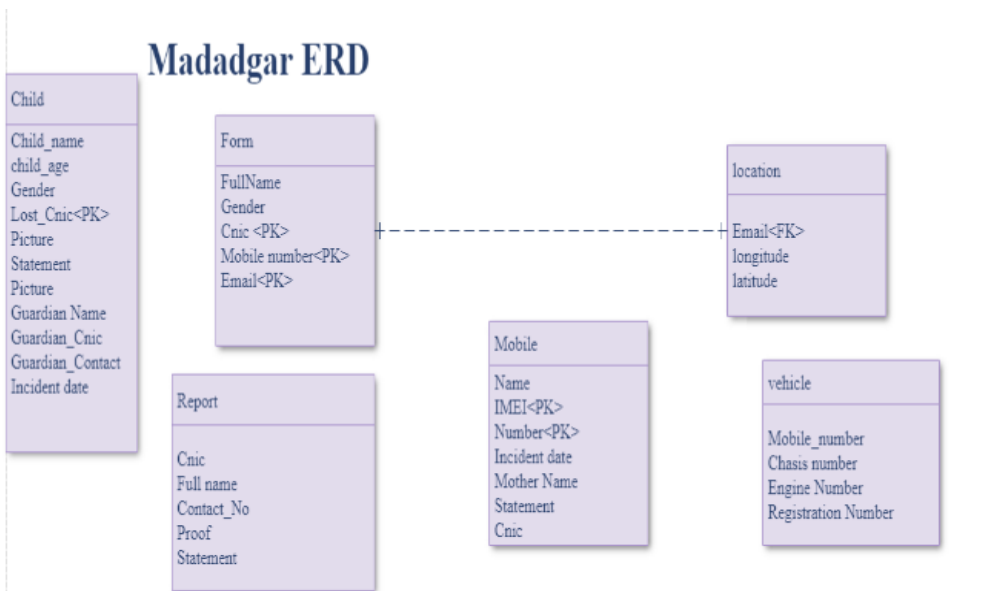
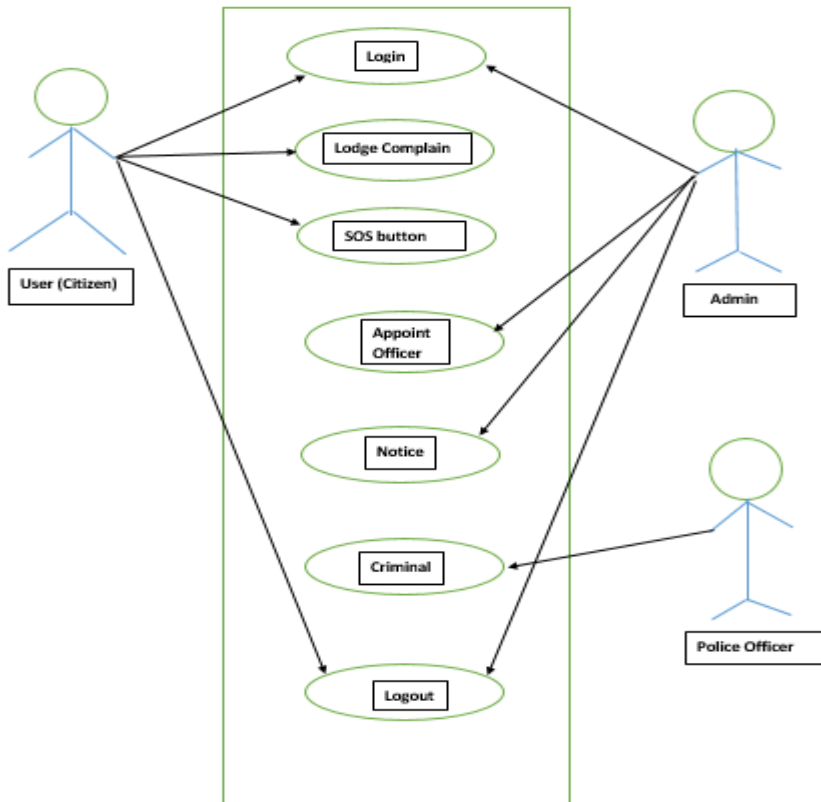

Figure-4

**C) Design and implementation:**

- ERD Diagram: The entity relationship diagram shows in figure identifies the entity. The database is divided into 6 tables child, Forms, Location, Report, Mobile and Vehicle..For every functionality there is seperate table to store data.Each table contains revelant fields and primary key to store data.
- **Use case diagram:**Following use case diagram shows the details of requirements.It focuses on three actors and seven use cases that are related to actions.The procedure to use Madadgar Application is as follows: (1)User can login and register himself ,lodge complain , Press SOS Button in emergency and logout. (2)Admin can login ,see the information about who have submitted complains,and Appoint officer to take action for emergency user. (3)Officer help the citizen and investigate for crime.



**Use Case diagram**

**Figure-5**

- **Architectural Design** To develop this app we have chose 3 layer architecture.The figure shows the architectural design of Madadgar app.Here the implementation is divided into 3 main layers i.e presentation layer,bussiness logic ,backend layer. (1)**Presentation layer**:The front end of the app is map as presentation layer.It contains the GUI() for end user.It is basically made of android 's activity.xml.The work of this layer is have interaction with user through user friendly forms and to send/recieve to bussiness logic layer for further processing. (2) **Business logic layer**:This second layer is the most important layer of the app.It takes data from.presentation layer and do some processing on data.It also recieve/send to data layer and interact with google api if needed.(3)**Data layer**:This layer contain firebase database.It store entire data of the app.It is divided into two sub part.First one is realtime database of firebase which store text data of the app.Firebase storage is another part which stores pictures ,videos recieved from user.

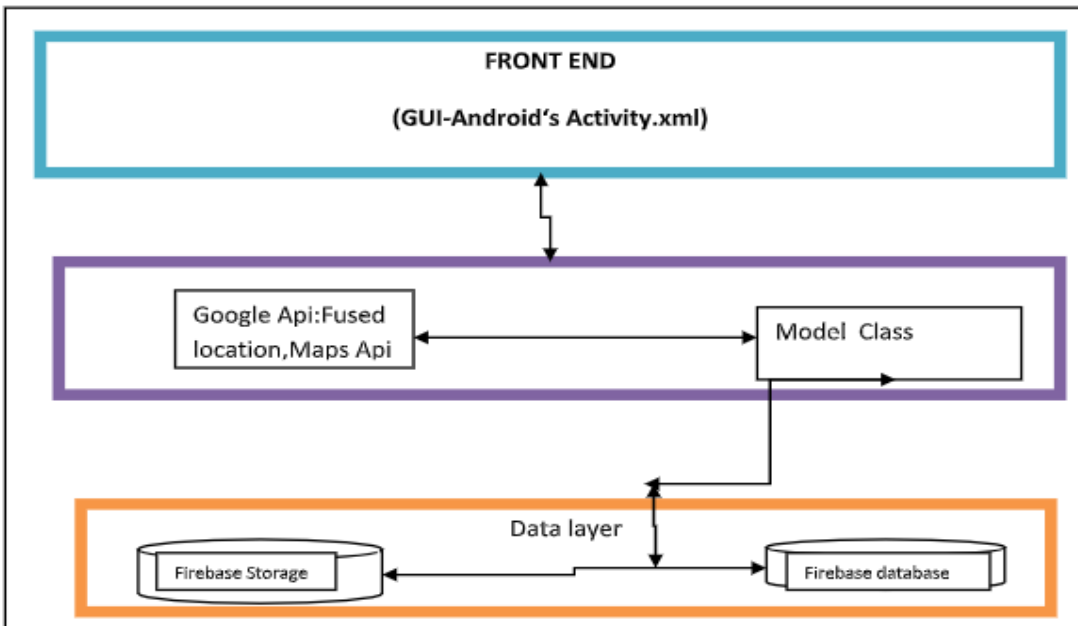

**Figure-5**

### Architectural Design

**Process Flow Diagram:**Below is the process flow diagram of Madadgar application,which shows the whole application's features,forms and storage of data in Firebase database

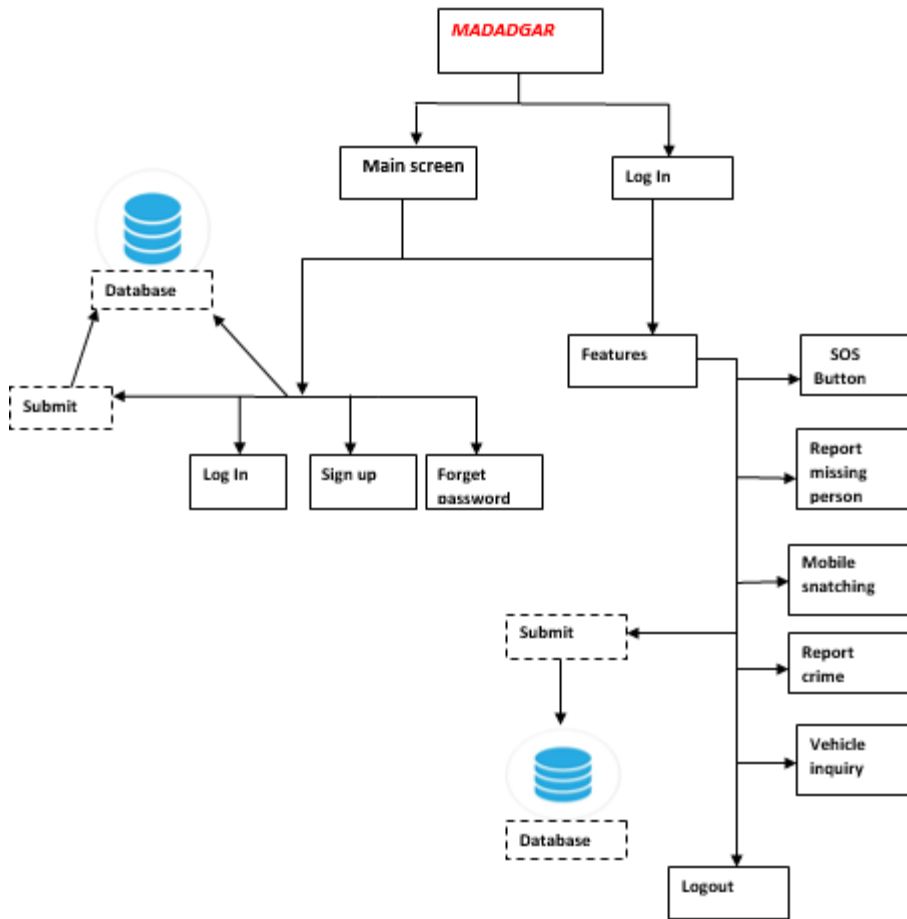

Figure-7

## V- Implementation

The app is divided into three sub-modules. The first module is GUI of app which stand for graphical user interface which is frontend of app . This include designing user friendly form for user login ,registration and different complain lodge forms . Whenever user install the app for first time it will required to register himself by providing some specific fields. Through login page user can enter his username and password and can use desired services .Figure shows the registration and login page of Madadgar app. The second module include server which are the front technologies by which whenever user install the app can registered himself by providing essential details. Third module is database in backend. The essential detail like id, password is saved in database. The complain lodge forms will also be connected with database. After submitting the form all details will be first saved in database which will help CPLC to take action.

### a) Function of the app

MADADGAR (Anti theft-SOS) is a mobile app for citizen of Pakistan. In this project the user without dialing CPLC helpline will be able to register complains through user friendly forms by

any part of the world. It will be a single platform that will be a gateway to lodge any type of complains whether it is child lost, robbery, or any conflict in families. It will become an important part of people’s everyday lives as it combines simplicity and usefulness and brings Pakistani Forces and citizens on one single platform .The most highlighted feature is SOS button.

**b) Features:**

- **Report of robbery(mobile):**Through user friendly ,victim will be able to file a complain in few minutes regarding any snatching he faced. The hassle of making phone call to CPLC will be eliminated.
- **Report of child lost:** A child lost/runaway can be report to cplc.Through forms user will be to upload picture of lost person and can provide other important details [6]. The require details of reporting child are mention in fig-(a)
- **Report of vehicle robbery:** A report of vehicle lost/snatch can be lodged through app.A user will be able to provide detail of the car (number plate, car color, engine number).For reference see Fig-(a)
- **Verify while buying a car or bike:** By app user can easily verify the particulars of the vehicle he intend to buy through Stolen / Snatched Vehicles Database of CPLC
- **Sos-button:** The user will also be able to call for help in case of emergency by pressing SOS button by which exact location of the user will send to response center [8].

**Report any crime:** people can upload the video, picture on app to report the proof of any illegal activities [3] .

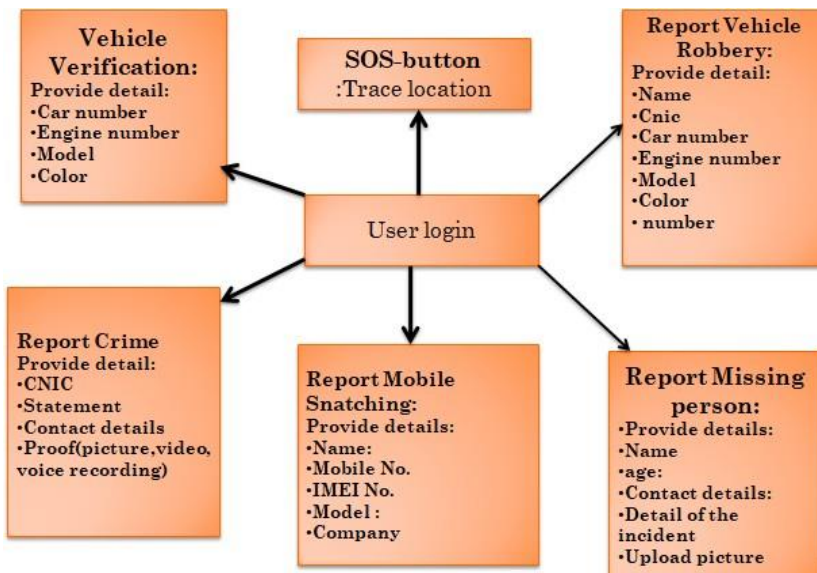

**Figure-8(a)-block diagram of app**

**c) PROPOSED MODEL:**

The proposed model in fig(b) explains the flow of the app. When user installs this application in user installs this app in the device it is required to register himself by providing necessary detail like the e-mail id and mobile numbers .The Second step will be email/mobile verification by system .A code will be sent to User email/mobile for verifying the source of registration. After Successful registration the user can select the type of his service he required and can call for help by providing necessary details for required service as explained in fig(a).After submitting information the national security force will take required action.

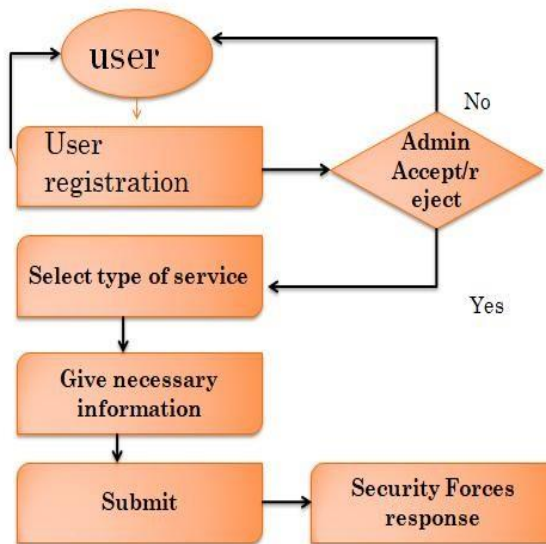

**Figure-8 (b)**



**Login Form  
Figure-9**



Dashboard



Registration Form

Figure-10

**Google Map API:** Google Maps is an online mapping service application and technology that supports a number of map-based services, including the Google Maps website, Google Ride Finder, Google Transit, and maps integrated on third-party websites via the Google Maps API. You can embed Google Maps in your own web sites using the Google Maps JavaScript API. It is possible to embed Google Maps using the Google Maps API. When user press the SOS button, his location will be trace by using Google Map API.

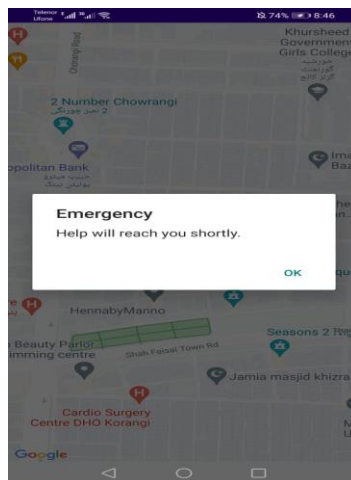

After SOS Button press

Figure-11



Person missing form interface. It features a grid icon and an 'UPLOAD' button at the top. Below are input fields for: Child Name, Bayform/CNIC, Age(XX), Guardian CNIC, Male/Female, Guardian Name, Incident Date, and Contact No. A large text area for 'Incident Details' is at the bottom, followed by a 'SUBMIT' button.

Person missing form



Mobile lost Report Form interface. The title is 'Report Lost/Stolen Mobile'. It includes input fields for: Full name, IMEI, Mobile Number, CNIC, Mother name, and Incident Date. A large text area for 'Statement' is at the bottom, followed by a 'SUBMIT' button.

Mobile lost Report Form

Figure-12

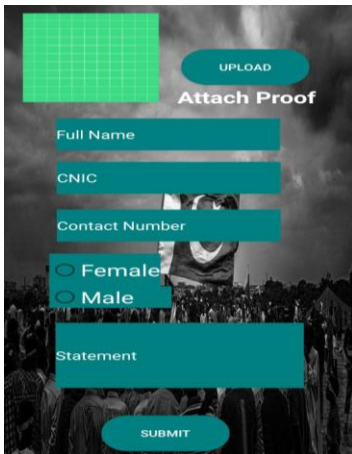

Report crime form interface. It features a grid icon and an 'UPLOAD' button at the top, with the title 'Attach Proof'. Below are input fields for: Full Name, CNIC, Contact Number, and radio buttons for Female and Male. A large text area for 'Statement' is at the bottom, followed by a 'SUBMIT' button.

Report crime form



Verify Vehicle Form interface. The title is 'Verify Vechile'. It includes input fields for: Enter Number for SMS, Engine No., Registration No., and Chasis No. A 'SUBMIT' button is at the bottom.

Verify Vehicle Form

Figure-13

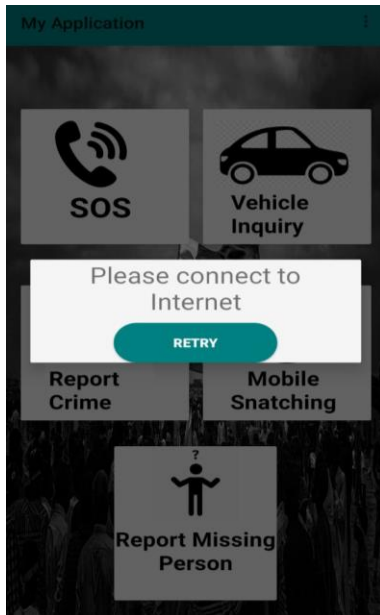

Internet Connection

Logout

Figure-14

#### d) Testing:

Testing any app is a fundamental part of the app development process. By running tests against your app you'll be able confirm your app's functionality, performance, and ease of use before you launched it. Following tests were performed on Madadgar app different interfaces with the help of firebase automated tester [10].(1) Unit testing: Each Functionality was tested separately to confirm that they are fit to use. The main goal was to check individual functionality and responsiveness.(2) Integration Testing: After unit testing some of modules were joint as one part. The tests were performed to know how each module react when its combine with other module.(3)System Testing: In this testing all modules was combine as a whole system and help to check the app overall functionality and performance.

#### VI- Conclusion

This paper presents novel of MADADGAR( anti-theft) app for android devices.This mobile app is specially for Security Forces. For first time initialization the app will ask user to login/register so his essential information is saved in security forces database. The app will allow the user to lodge complains, call for help through user friendly forms immediately and also track his location whenever the user call for help through SOS-button.

## VII- Future scope

In future we would like to increase our domain by implementing this app with sensors. The user will be able to call for help, by pressing the SOS-button in his locket or ring. The sensor in locket or ring will help security forces to trace his current location.

## VIII- Acknowledgement

The authors would like to acknowledge to all those who guided us for MADADGAR APP. We express our deep sense of gratitude to our Project Supervisor Sir Muhammad Ayoub Kamal and institution IoBM.

## IX- REFERENCES

- [1] H. Abbas, "Role of Pakistan Police in Counterinsurgency," no. 5, 2008, [Online]. Available: [http://www.brookings.edu/~media/Files/rc/papers/2009/06\\_counterinsurgency\\_abbas/06\\_counterinsurgency\\_abbas.pdf](http://www.brookings.edu/~media/Files/rc/papers/2009/06_counterinsurgency_abbas/06_counterinsurgency_abbas.pdf).
- [2] A. Ush, S. Kha, and Z. Aliga, "Anti-Theft Applic," pp. 365–369, 2014.
- [3] H. Garg, "Anti -The Application for Lost or Misplaced Android Phones Anti -Theft Application for Lost or Misplaced Android Phones."
- [4] A. Salahuddin, "Crime and Institutional Response : A Study of Mobile Snatching and Street Assaults in Pakistan Proposed Framework of Analysis , Review of Literature and," vol. 6, no. 2, pp. 43–52, 2014.
- [5] J. Fu, Y. Zhou, and X. Wang, "Component-based permission management of Android applications," *Softw. - Pract. Exp.*, vol. 49, no. 9, pp. 1402–1418, 2019, doi: 10.1002/spe.2734.
- [6] K. Xu, W. Zhang, and Z. Yan, "A privacy-preserving mobile application recommender system based on trust evaluation," *J. Comput. Sci.*, vol. 26, pp. 87–107, 2018, doi: 10.1016/j.jocs.2018.04.001.
- [7] U. Tunku and A. Rahman, "App To Assist in Emergency Situations Using Best Time," 2019.
- [8] H. Maryam, M. Ali, Q. Javaid, and M. Kamran, "A Survey on Smartphones Systems for Emergency Management (SPSEM)," *Int. J. Adv. Comput. Sci. Appl.*, vol. 7, no. 6, pp. 301–311, 2016, doi: 10.14569/ijacsa.2016.070639.
- [9] D. A. Alexander and S. Klein, "Kidnapping and hostage-taking: A review of effects, coping and resilience," *J. R. Soc. Med.*, vol. 102, no. 1, pp. 16–21, 2009, doi: 10.1258/jrsm.2008.080347.
- [10] S. Groß, A. Tiwari, and C. Hammer, "ThiefTrap -- An Anti-theft Framework for Android," in *Security and Privacy in Communication Networks*, 2018, pp. 167–184.
- [11] D. Gogoi and R. K. Sharma, "Android based emergency alert button," *Int. J. Innov. Technol. Explor. Eng.*, vol. 2, no. 4, pp. 26–27, 2013, [Online]. Available: <http://goo.gl/V7L6X6>.
- [12] A. Mohammed, A. Ali, and A. A. Awooda, "Design and Implementation of Anti-Theft Vehicle Tracking System with Android App A Research Submitted in Partial Fulfillment for The تصميم وتنفيذ نظام مضاد للسرقة لتعقب المركبات ب تطبيق اندرويد .Requirement of The Degree of M.Sc. in Electronic Engineering Department of Computer and Network Engineering," 2019
- [13] M. Kadibagil, "Position Detection and Tracking System," *IRACST -International J. Comput. Sci. Inf. Technol. Secur.*, vol. 4, no. 3, pp. 67–73, 2014.
- [14] B. Liu, N. Liu, G. Chen, X. Dai, and M. Liu, "A Low-Cost Vehicle Anti-Theft System Using Obsolete Smartphone," *Mob. Inf. Syst.*, vol. 2018, 2018, doi: 10.1155/2018/6569826.
- [15] Y. Cheon, "Multiplatform application development for android and Java," *Proc. - 2019 IEEE/ACIS 17th Int. Conf. Softw. Eng. Res. Manag. Appl. SERA 2019*, pp. 99–103, 2019, doi: 10.1109/SERA.2019.8886800.
- [16] E. Chin, A. P. Felt, K. Greenwood, and D. Wagner, "Analyzing inter-application communication in Android," *MobiSys '11 - Compil. Proc. 9th Int. Conf. Mob. Syst. Appl. Serv. Co-located Work.*, pp. 239–252, 2011, doi: 10.1145/1999995.2000018.
- [17] M. A. Kamal, M. M. Alam, and M. S. Mazliham, "Routers Perspective Simulation-Based Analysis of EIGRP and OSPF

- Routing Protocol for an Organizational Model,” *Int. J. Innov. Technol. Explor. Eng.*, vol. 9, no. 4, pp. 2013–2019, 2020, doi: 10.35940/ijitee.b6509.029420.
- [18] M. Kumar, “Serverless Architectures Review, Future Trend and the Solutions to Open Problems,” *Am. J. Softw. Eng.*, vol. 6, no. 1, pp. 1–10, 2019, doi: 10.12691/ajse-6-1-1.
- [19] M. A. Kamal, H. W. Raza, M. M. Alam, and M. Mohd, “Highlight the Features of AWS, GCP and Microsoft Azure that Have an Impact when Choosing a Cloud Service Provider,” *Int. J. Recent Technol. Eng.*, vol. 8, no. 5, pp. 4124–4232, 2020, doi: 10.35940/ijrte.d8573.018520.
- [20] I. -, S. M. Ali, M. Alam, and M. M. Suud, “Review Of Security Issues In Internet Of Things (IoT),” *J. Indep. Stud. Res. Comput.*, pp. 1–14, 2020, doi: 10.31645/20.
- [21] M. A. Kamal and M. Maknoja, “Camera With live Streaming,” vol. 13, no. May 2019, pp. 6–9, 2020.

# DIVERSITY AND UTILIZATION OF DYNAMIC PROGRAMMING (DP): A BRIEF OVERVIEW

<sup>1</sup> Maryam Younus, <sup>2</sup>Iqra Rehman

<sup>1</sup>Trade development of Pakistan, <sup>2</sup>Ziauddin University, Karachi

**Abstract-** "Dynamic programming" is a popular technique for handling an extensive range of Problems with sequential decision-making in the context of unpredictability. It permits us to calculate optimal choice rules, which identify the most likely decision in every given case. This article evaluates DP's evolution and compares because of the paucity of applications in the real world in different field like finance, operations research, economics, engineering, and artificial intelligence (AI) to help businesses and individuals make better decisions. The complexity of statistically modeling many real world choice concerns, as well as the fuzziness of many real-world decision issues, are important hurdles to broad application of DP in practical situations. Despite this, this review research found a number of successful experiments, and it was decided that DP provides considerable assurance for better decision making. The scientifically untenable concept of unconstrained rationality is challenged, as are the challenging choice issues that people encounter on a daily basis. Additionally, because of the sequential decision-making and simplicity of managing non-linear goal roles and constraints, it is considered a good approach for optimum operation. Although, owing to the complexity of the 'curse of dimensionality,' applying DP to significant and multi-directional situations is not very promising. Some of the algorithms developed to solve this problem for DP include incremental DP, discrete differential DP, DP with consecutive approximation, and incremental DP with successive approximation. Furthermore, in each of these instances, selecting a starting trial route, obtaining an optimal solution and the number of iterations necessary for convergence are all hard to enforce.

**Keywords:** Algorithm, dynamic programming, optimization, artificial intelligence, bounded rationality, computational complexity.

## I. INTRODUCTION

Since its inception in the mid-nineteenth century by "Richard Bellman," dynamic programming (DP) has been successfully applied to a wide range of issues in a variety of areas [1, 2]. One of the most important features of DP is potential to adjust for a structure's dynamics, and it is usually utilized by operations investigators to address problems existence decisions. DP can also handle a wide range of cost and/or reward functions, unlike the bulk of optimization approaches. Because of its versatility, it is envisaged that DP will be employed in a variety of fields, including artificial intelligence, control, economics, and operational research. DP, on the other hand, has several disadvantages. The capacity of a dynamic program grows swiftly in proportion to the problem's

---

<sup>1</sup>[maryam.younus@tdap.gov.com](mailto:maryam.younus@tdap.gov.com),  
<sup>2</sup>[iqrarehman091@gmail.com](mailto:iqrarehman091@gmail.com)

complexity. This is known as the "curse of dimensionality," and it has been the most difficult aspect of applying DP techniques to real-world problems. Investigators have advocated a variety of estimation techniques, including state aggregation and value function evaluation, to solve large dynamic problems, taking into account the computational complexity that result from the curse of dimensionality [3].

Richard Bellman used the term DP in 1950 to describe a recursive approach for determining optimum strategies and decision criteria for a broad variety of dynamical, successive decision making scenarios including ambiguity[4]. The invention of differential equations (DP) use of mathematical application as a principal indicator of mathematical modeling revolutionized the way we understand economic principles. It is undoubtedly the most essential tool in game theory, macro and micro economics [5, 6]. Many combinatorial optimization issues are computationally intractable. In practice, however, we are typically happy with reasonably excellent results, and approximation algorithms are crucial in this regard. There are a number of tools that may be used to create approximation algorithms. The greedy technique, which directly creates approximate solutions by gradually calculating the values of variables based on some local knowledge, is likely the most prevalent.[7].

## II. DISCUSSION ON THE UTILIZATION OF DYNAMIC PROGRAMMING

Dynamic programming (DP) is the process which can easily be utilized to solve problems related to scheduling. Many researches executed the dynamic programming in the scheduling problems. Other than scheduling exercises [8] offered process of heuristic solution by implementing dynamic programming to determine the employment of out-sourcing as a mean to overcome the disruptions related to the supply chain in manufacture scheduling for unexpected consumer orders. The while a study conducted by [9] in this study author established a program to schedule surgical procedure at the hospital to reduced time of waiting, overtime in operating room and bed availability in ward. For that dynamic program was used to achieve the required output.[10] A self-styled polynomial DP has been putted in to operation for determining the outstanding dates and costs required in the allocation of resources delivery of batch to control the delay in jobs.

Furthermore[11] planned a schedule for aircraft landing on a single run way through dynamic programming.[12]an exact algorithm was proposed by the author to discover the optimal sequences for a shop scheduling issue depend upon DP.[13]in this study author developed a model

of stochastic DP to obtain optimization by a proposed schedule of aircraft replacement keeping variation in the market demand and aircraft status in the focus. Moreover[14]build up approximate dynamic programming (ADP) algorithms to solve stochastic project scheduling problems. In a study conducted by [15]build-up a schedule using adaptive DP to maximize the patients level of satisfaction which is dependent on uninterrupted meetings.[16]a new version of DP algorithm was offered for the solution of problems related to scheduling of tasks perform individually with uniform out-standing due date and to reduce unpunctuality weight of task.

Additionally, for proper management regarding technology replacement which is directly associated with proficiency can be managed via DP. It can be a major tool for solving the problems as stated in [17].

Moreover [18] The application of DP in E-grocery stores where the aim of utilization was to develop a method to control the demand of the online orders through the cost of delivery time. Meanwhile, another study[19]build up a model under DP for the process of coal mining investment related environmental decision making associated with the optimization of draft.[20] The research study planned a DP with new idea which made a tradeoff between cost for the draft and reliability. Also[21] implemented DP in creating a balanced assembly line to constrain optimal resources. Many of the researches used DP to solve stock related problems. For example[22]Applied multi stochastic DP to tackle stock replenishment problem in a reverse supply chain and [23] discovered the solution of a multi localities stochastic stock system through forward approximate DP[24]In this study authors initiated a model which was based on a DP for a limited scope of solo manufactured goods with doubtful likelihood division of demand. Moreover[25] recursion in DP was included as mixture of integer linear programming in stock related scheduling issues.

Difficulties in the knapsack, a number of instigators believed on the implementation of DP in addition. Furthermore in[26]study projected an algorithm based on DP for the knapsack issues with complex that generally applicable in Planning of manufacturing, [27] In the following study 2DP algorithms where the 1st one was projected for complexity of linearity on the quantity of items, whilst the 2nd one was used for complexity at the capacity of the knapsack. Furthermore[28]proposed a DP for packing knapsack with lowest amount of cost and optimal profit. Added; that utilization of DP in routing and transportation problems is very common and frequent. [29]

In this study authors proposed a model of DP was created and run for a multi model transporter for reducing the transportation cost. [30] In this research, two different algorithms DP and ant colony have been merged to get optimized results in disaster condition in deployment of emergency material emergency via transportation.

Study done by [31] offered an approximate DP move towards to optimize time for handling and find out space to store in a coil warehouse. In the interim [32] put forward a markovian decision model and approximate DP to resolve vehicle routing problem for emissions minimization, Where [33] genetic algorithm and exact DP procedure was combined for green vehicle routing and scheduling problem. DP is used to deal with plantation as well. [34] illustrated the utilization to optimized model to replanting policy that deems CO<sub>2</sub> emission and commercial advantages. In this research paper the best schedule was obtained for the best total cost of picking tea by using DP.

### III. ALGEBRAIC DYNAMIC PROGRAMMING (ADP)

Exact solutions of many problems can be obtained through dynamic programming (DP) algorithms especially in biology computations, more over in sequence alignment, scoring of phylogenetic trees and hidden Markov models (HMMs). Evaluation of distribution of score, performing stochastic sampling and competitions for optimal solutions can be done via structurally analogous algorithms. As we can learn in ADP through a severe division of state space traversal, encoded as algebra, and rule of choice. The main component of the ADP is the application of yield examiners who work on the structures statistics, commonly ordered and string trees. The unaligned properties of computation such that; HMMs posterior probability, RNA folding (partition functions) which involves the two distinct combinations other than the algorithms related to intimate, recognized as in and outside recursion whilst the classical theory of AD sheltered only the inside recursions [35].

### IV. DP PROBLEM APPROACHES

Practically all genuine DP issues must be solved numerically. conventional techniques that rely heavily on human input and programming, and machine learning and reinforcement learning algorithms that can discover optimal solutions via trial and error experimentation [36]. In the AI and DP research literatures, the term "learning" refers to two things: Learning the optimum decision criterion and problem paradigm, which includes the DM's incentive or objective utility

and the conservation of momentum managing system parameters in the DP problem, but rather how decisions affect rewards and situations in the DP predicament. Learning the optimum decision criterion and issue paradigm, which includes the DM's reward or goal function and the conservation of momentum controlling system parameters in the DP issue, is less important than understanding how decisions effect rewards and situations in the DP predicament. The term adaptive oversight is used in the DP and manage literatures to describe situations in which the DM attempts to become skilled at the formation of the DP predicament while also attempting to make proper decision, in cases like the multi-armed bandit conundrum, this is likely to result in the typical tradeoff among exploration and exploitation [37].

According to the researches, the essential element and approximated solutions are determined before the decision rule is being used to make or propose judgments, and when decisions are taken, the algorithm updates its estimate of the problem structure and the ultimate decision rule. Several algorithms which are real time learning based have the benefit of not having precise utility functions for the fundamental inclinations, assumptions, and "laws of motion" that ensures the integrity of the basic problematic situation. An additional notable difference is either the learning is evaluated.

The presence of a professional DM whose conduct can be monitored and employed to train a decision rule, either through simple extrapolation approaches that understand preferences and laws of motion for state variables from scrutinized manners of specialist DMs are assumed in supervised learning. Un-supervised learning, such as RL, "comes into play" when examples of desired behavior are unavailable but instances of conduct may be scored based on some performance decisive factor[38].

It is used to find optimal decision rules in 'games against nature' and sub-game perfect equilibrium of dynamic multi-agent games, and competitive equilibrium in dynamic economic models. DP has enabled economists to formulate and solve a huge variety of problems involving sequential decision making under uncertainty, and as a result it is now widely regarded as the single most important tool in economics.[4]

## V. DP APPLICATIONS TO IMPROVE DECISION MAKING

DP is only employed in a many real-world scenarios. It is reasonable to assume that the stakes for implementing profit-maximizing programs are relatively high; consequently early adopters of DP should be profitable, inventive entities that can generate the resources needed to solve tough

decision. Nonetheless, regardless of the fact that It has not conducted a systematic investigation, several companies that are likely to implement DP look hesitant or unwilling to discuss it. Multi-period optimization is used in some cases, however it should not be considered DP[36]. Additional issue that restricts the use of DP is that the target function that many organizations are optimizing is hazy and ambiguous. In economics, the default assumption by government companies is to maximize their market share. This is the expected trickle of future earnings reduced at a risk-adjusted discount factor. Conversely, a significant body of financial evidence on the disproportionate stock price volatility market prices poses serious reservations about what the firm's net worth is comparable to its fundamental value, which is the estimated present value of its future income flow. Even if all of the other incentive difficulties associated with running a business could be handled, it means that the aim function of an administrator should never longer be to maximize predicted discounted profits to the degree that stock market values include a strong and systematic noise component. The absence of contrivances and procedures to assess whether a DP-based decision solution should be developed or acquired creates enough extra income or profit to justify its adoption is a final obstacle to its deployment. There are very few examples of method validation conferred, but more rigorous systematic process potentially help to increase the integrity of decision based on dynamic programming aids and widen their range of real world implications. [36].

## VI. NUMERICAL ASPECTS OF DYNAMIC PROGRAMMING

Dynamic programming that breakdown the way out to resolve hurdles recursively connected simpler set of sub-problems. This is taken from Bellman's principle of optimality "An optimal policy has the property that whatever the initial state and the initial decision are, the remaining decisions must constitute an optimal policy with regards to the state resulting from the first decision." [39]the perceptive is that using backward induction to solve a dynamic game generates an optimized decision rule that complies to Bellman's principle of optimality Backward induction is based on the optimality principle, which uses time as the indicator, but [40]Backward induction for dynamic games has been generalized to established state recursion. They described a problem-state ordering that formally expresses the perceptual conception of diamentiality. This figure demonstrates how to disintegrate the SDP into phases; this can be used as a backward induction course indication instead of the normal time indexing. While it is technically possible to recast and solve optimum decision rules for SDPs as statically, "approachable" optimum concerns, it is often

significantly more efficient to solve them using DP, which decomposes the overall issue into a series of undersized, a lot more manageable sub-problems. DP emerged in the mid nineties as a consequence of a convergence of work on optimum hydropower reservoir operation, early statistical decision theory, optimal inventory control, and game theory at the same time that the first digital computers[49] were being developed [41].Despite the fact that the term programming conjures up images of computer programming, since computer systems were incapable of tackling most real DP challenges, much early work on DP was theoretical. In fields like operations research, resource management and engineering management of electricity grids and power generation, communications and network[46] routing, the utility and flexibility of DP for formulating and solving a wide range of problems and games of practical importance and relevance was quickly recognized [3].Dynamic games have been widely used in economics, where businesses and customers are supposed to be rational actors with optimum decision rules governing their behavior. As a result of Its application in the formulation of inferential and counterfactual strategy projections, In econometrics, there is an empirical evidence on numerical method and estimation of "dynamic structural models"[42].Because of the large number of SDP applications, There's also a desire for more powerful numerical techniques on digital computers to answer or estimate the services to major DP issues, which are developing at exponential rates owing to the digital revolution and countless technical improvements encapsulated in "Moore's Law." Many actual DP issues, on the other hand, might be huge in size or dimensions[43]. In DP issues when the DM is unknown, The method of Bayesian learning is used when the DM does not observe the true state or does not completely comprehend the law of motion driving the state variables, Bayesian learning is used, and one of the DP problem's state variables is the posterior distribution over these uncertain values. Unless the problem satisfies restrictive restrictions for the posterior to be a member of a conjugate family, it is an infinite dimensional state variable. Even if we approximate this posterior with a finite approximation, the result is a finite dimensional DP problem with a very high dimension.

The amount of potential values can be enormous yet in situations or games when there is a limit to the size of the state space. Chess has roughly 1050 potential board locations, whereas there are more than 10100 positions in the game of checkers. According to created the phrase "curse of dimensionality" to characterize the exponential growth in computer time required to tackle more concrete and specific DP problems, there's more than the number of atoms in the observable world

[39]. The researcher did not indicate if the constraint of dimensionality is a permanent "limit to science" or merely a source of concern that might have been solved with better techniques and speedier computers. In the following literature on knowledge based complexity in computer science, the "curse of dimensionality" is stated as the computing[47] of an explicit model that identifies by some mathematically related operations such as integrations. To find an accurate output, a vast quantity of data about the underlying function is necessary, yet real world computers and algorithms can only use a limited amount of data to find an optimal options [44].With this architecture, computer programmers were able to characterize a variety of mathematical issues connected to the curse of dimensionality, confirming that it is a basic "limit to science" that no algorithm, no matter how sophisticated, can evade. Any mathematical issue that is intractable and prone to the curse of dimensionality is described as such by computer programmers. In the worst-case computing expenditure of producing an approximation to the true solution, the number of continuous variables or dimensionality of the issue grows exponentially.

## VII. EMPIRICAL DYNAMIC PROGRAMMING AND THE IDENTIFICATION PROBLEM

The advancements in numerical DP paved the door for a burgeoning literature on empirical estimate and testing of SDPs and dynamic games. The existing knowledge on estimate of dynamic labor demand schedules in a linear quadratic framework began to condense around the end of the 1970s, at the same time as a number of publications appeared that gave diverse methodologies. To develop ancient discrete optimized algorithm DP is considered as a influential and common technique. To crack the numerous difficult problems related to computer vision like detection of curve, completion of contour, matching of stereo and alignment and matching of distort object can be solved by using DP algorithm. To breakdown the problem into sub problem is the key idea of DP like that; (I) provide a solution to the sub-problems, where the solution of the problem can be computed quickly for the main problem, and (II) recursively solution of the sub-problem can be done efficiently in term of each other. The significant characteristic of DP is that the way out of a sole sub-problem is repeatedly used for cracking numerous bigger sub-problems. In the DP algorithm the provided solution not further needed to be verified and there will not be needed of re-computations. This is the major benefit which differentiates DP algorithms from classical recursive algorithms. Comparable to shortest paths algorithms, DP relies upon optimal sub-structure property. That creates the possibility to solve sub-problem using solutions of smaller sub-problems.

A DP algorithm may be thought of as a way for filling up a table, with each table entry corresponding to one of the sub-problems we must solve. The DP algorithm iterates through table entries, calculating a value for the current item based on the values of previous entries. Often, a simple recursive equation describes the value of one entry in terms of the values of other entries, but calculating a value might be more difficult. [45].

### VIII. FUZZY DYNAMIC PROGRAMMING

There is availability of fuzzy system literature in the context of verity of situations and several algorithms for their treatments, which occurs due to clustered data in fuzzy environment. As an extension of conventional DP Bellman introduced a model for fuzzy scenarios. Two models of fuzzy DP were initialized and switched into algorithms. Comparison of heuristics-based performance of algorithm was done. The usage of dynamic programming in data presented in clustered form is substantial way to resolve the issue.

Though, there is a brief discussion on the conception about the multi stage decision making in fuzzy environments as a preamble growth of the algorithm for cluster analyzation. For the modeling and optimization of any process in a fuzzy environment fuzzy DP is an effort to inoculate the theory of fuzzy sets. The DP based algorithm approaches steadiness considerably quicker as compared to the algorithms based on heuristic. Fuzzy DP is accurate for both the unenthusiastic as well as positive assessments. A main benefit of fuzzy DP which is not stated here is the possessions that the fuzzy cluster's optimal numbers can be find out through the algorithm via grouping procedure. Fuzzy DP considered as an efficient instrument for the construction of an algorithm that is particularly well matched for fuzzy data in clusters. Optimum and stability components of DP appear to have also been relocated to its fuzzy analog. The program is stress-free to write and implement. Additional, in the one directional description, striking computational problems are the typical characteristic of DP which were encountered with the execution of the algorithm [46].

### VIII. CONCLUSION AND FUTURE RESEARCH DIRECTION

Dynamic programming (DP) is an exceptionally strong approach for handling a wide range of uncertain sequential decision problems. Indeed, it's difficult to imagine an issue that can't be expressed and solved with Dynamic programming. The discipline has been transformed by the adaptability and strength of DP, and it has offered a basic concept that has resulted in some of the

most astounding AI successes. The complexity of using DP to design and answer the very multifaceted, ambiguous and depravedly described decision issues that entities and businesses come upon on an everyday basis is the primary grounds for its limited number of real-world implementations. Although DP has been quite efficient for academic modeling, articulating and addressing ultimate decision issues as mathematical problems has proven to be significantly more challenging. It is commonly understood that as computer power and algorithms improve, so does the range of real-world problems that DP can handle. Despite massive computer influence and decades of research that have provided a profusion of substitute clarification strategies for difficulties of dynamic programming, the number of known real-world utilizations of DP remains surprisingly limited even now.

#### REFERENCES

- [1] Elton, E.J., and Gruber, M.J.: 'Dynamic programming applications in finance', *The Journal of Finance*, 1971, 26, (2), pp. 473-506
- [2] Bellman, R.: 'The theory of dynamic programming', *Bulletin of the American Mathematical Society*, 1954, 60, (6), pp. 503-515
- [3] Powell, W.B.: 'Approximate Dynamic Programming: Solving the curses of dimensionality' (John Wiley & Sons, 2007. 2007)
- [4] Rust, J.: 'Dynamic programming, the new palgrave dictionary of economics, edited by steven n', Durlauf and Lawrence E. Blume, 2008
- [5] Adda, J., and Cooper, R.: 'Dynamic economics: quantitative methods and applications', in Editor (Ed.)^(Eds.): 'Book Dynamic economics: quantitative methods and applications' (The MIT Press, 2002, edn.), pp.
- [6] Aguirregabiria, V., and Mira, P.: 'Dynamic discrete choice structural models: A survey', *Journal of Econometrics*, 2010, 156, (1), pp. 38-67
- [7] Yagiura, M., and Ibaraki, T.: 'The use of dynamic programming in genetic algorithms for permutation problems', *European Journal of Operational Research*, 1996, 92, (2), pp. 387-401
- [8] Liu, F., Wang, J.-J., Chen, H., and Yang, D.-L.: 'Machine scheduling with outsourcing: coping with supply chain uncertainty with a second supplying source', *The International Journal of Logistics Management*, 2014, 25, (1), pp. 133-159
- [9] Astaraky, D., and Patrick, J.: 'A simulation based approximate dynamic programming approach to multi-class, multi-resource surgical scheduling', *European Journal of Operational Research*, 2015, 245, (1), pp. 309-319
- [10] IRasti-Barzoki, M., and Hejazi, S.R.: 'Pseudo-polynomial dynamic programming for an integrated due date assignment, resource allocation, production, and distribution scheduling model in supply chain scheduling', *Applied Mathematical Modelling*, 2015, 39, (12), pp. 3280-3289
- [11] IBennell, J.A., Mesgarpour, M., and Potts, C.N.: 'Dynamic scheduling of aircraft landings', *European Journal of Operational Research*, 2017, 258, (1), pp. 315-327
- [12] IGromicho, J.A., Van Hoorn, J.J., Saldanha-da-Gama, F., and Timmer, G.T.: 'Solving the job-shop scheduling problem optimally by dynamic programming', *Computers & Operations Research*, 2012, 39, (12), pp. 2968-2977

- [13] Hsu, C.-I., Li, H.-C., Liu, S.-M., and Chao, C.-C.: 'Aircraft replacement scheduling: a dynamic programming approach', *Transportation research part E: logistics and transportation review*, 2011, 47, (1), pp. 41-60
- [14] Li, H., and Womer, N.K.: 'Solving stochastic resource-constrained project scheduling problems by closed-loop approximate dynamic programming', *European Journal of Operational Research*, 2015, 246, (1), pp. 20-33
- [15] Wang, J., and Fung, R.Y.: 'Adaptive dynamic programming algorithms for sequential appointment scheduling with patient preferences', *Artificial intelligence in medicine*, 2015, 63, (1), pp. 33-40
- [16] Tuong, N.H., Soukhal, A., and Billaut, J.-C.: 'A new dynamic programming formulation for scheduling independent tasks with common due date on parallel machines', *European Journal of Operational Research*, 2010, 202, (3), pp. 646-653
- [17] Wang, K.-J., and Nguyen, P.H.: 'Capacity planning with technology replacement by stochastic dynamic programming', *European Journal of Operational Research*, 2017, 260, (2), pp. 739-750
- [18] Yang, X., and Strauss, A.K.: 'An approximate dynamic programming approach to attended home delivery management', *European Journal of Operational Research*, 2017, 263, (3), pp. 935-945
- [19] Yu, S., and Gao, S.: 'A dynamic programming model for environmental investment decision-making in coal mining', *Applied energy*, 2016, 166, pp. 273-281
- [20] Tripathy, P.K., Dash, R.K., and Tripathy, C.R.: 'A dynamic programming approach for layout optimization of interconnection networks', *Engineering Science and Technology, an International Journal*, 2015, 18, (3), pp. 374-384
- [21] Quyen, N.T.P., Kuo, R., Chen, J.C., and Yang, C.-L.: 'Dynamic programming to solve resource constrained assembly line balancing problem in footwear manufacturing', in Editor (Ed.) (Eds.): 'Book Dynamic programming to solve resource constrained assembly line balancing problem in footwear manufacturing' (IEEE, 2017, edn.), pp. 66-70
- [22] Lekkakos, S.D., and Serrano, A.: 'Supply chain finance for small and medium sized enterprises: the case of reverse factoring', *International Journal of Physical Distribution & Logistics Management*, 2016, 46, (4), pp. 367-392
- [23] Meissner, J., and Senicheva, O.V.: 'Approximate dynamic programming for lateral transshipment problems in multi-location inventory systems', *European Journal of Operational Research*, 2018, 265, (1), pp. 49-64
- [24] Qiu, R., Sun, M., and Lim, Y.F.: 'Optimizing (s, S) policies for multi-period inventory models with demand distribution uncertainty: Robust dynamic programming approaches', *European Journal of Operational Research*, 2017, 261, (3), pp. 880-892
- [25] Rivotti, P., and Pistikopoulos, E.N.: 'Constrained dynamic programming of mixed-integer linear problems by multi-parametric programming', *Computers & Chemical Engineering*, 2014, 70, pp. 172-179
- [26] Chebil, K., and Khemakhem, M.: 'A dynamic programming algorithm for the knapsack problem with setup', *Computers & operations research*, 2015, 64, pp. 40-50
- [27] Claßen, G., Koster, A.M., and Schmeink, A.: 'The multi-band robust knapsack problem—a dynamic programming approach', *Discrete Optimization*, 2015, 18, pp. 123-149
- [28] Furini, F., Ljubić, I., and Sinnl, M.: 'An effective dynamic programming algorithm for the minimum-cost maximal knapsack packing problem', *European Journal of Operational Research*, 2017, 262, (2), pp. 438-448
- [29] Hao, C., and Yue, Y.: 'Optimization on Combination of Transport Routes and Modes on Dynamic Programming for a Container Multimodal Transport System', *Procedia Engineering*, 2016, 137, pp. 382-390
- [30] Liu, J., and Xie, K.: 'Emergency materials transportation model in disasters based on dynamic programming and ant colony optimization', *Kybernetes*, 2017, 46, (4), pp. 656-671

- [31] Yuan, Y., and Tang, L.: 'Novel time-space network flow formulation and approximate dynamic programming approach for the crane scheduling in a coil warehouse', *European Journal of Operational Research*, 2017, 262, (2), pp. 424-437
- [32] Çimen, M., and Soysal, M.: 'Time-dependent green vehicle routing problem with stochastic vehicle speeds: An approximate dynamic programming algorithm', *Transportation Research Part D: Transport and Environment*, 2017, 54, pp. 82-98
- [33] Xiao, Y., and Konak, A.: 'A genetic algorithm with exact dynamic programming for the green vehicle routing & scheduling problem', *Journal of cleaner production*, 2017, 167, pp. 1450-1463
- [34] Diban, P., Aziz, M.K.A., Foo, D.C., Jia, X., Li, Z., and Tan, R.R.: 'Optimal biomass plantation replanting policy using dynamic programming', *Journal of cleaner production*, 2016, 126, pp. 409-418
- [35] zu Siederdissen, C.H., Prohaska, S.J., and Stadler, P.F.: 'Algebraic dynamic programming over general data structures', *BMC bioinformatics*, 2015, 16, (19), pp. S2
- [36] Rust, J.: 'Has Dynamic Programming Improved Decision Making?', *Annual Review of Economics*, 2019, 11, pp. 833-858
- [37] Gittins, J., Glazebrook, K., and Weber, R.: 'Multi-armed bandit allocation indices' (John Wiley & Sons, 2011. 2011)
- [38] Barto, A.G., and Dietterich, T.G.: 'Reinforcement learning and its relationship to supervised learning', *Handbook of learning and approximate dynamic programming*, 2004, pp. 47-64
- [39] Bellman, R.: 'Dynamic programming, princeton univ', Prese} Princeton, 1957, 1957
- [40] Iskhakov, F., Rust, J., and Schjerning, B.: 'Recursive lexicographical search: Finding all Markov perfect equilibria of finite state directional dynamic games', *The Review of Economic Studies*, 2015, 83, (2), pp. 658-703
- [41] Massé, P.: 'Application des probabilités en chaîne à l'hydrologie statistique et au jeu des réservoirs', *Journal de la société française de statistique*, 1944, 85, pp. 204-219
- [42] Rust, J.: 'Numerical dynamic programming in economics. H. Amman, D. Kendrick, J. Rust, eds. *Handbook of Computational Economics, Chapter 14*', in Editor (Ed.)^(Eds.): 'Book Numerical dynamic programming in economics. H. Amman, D. Kendrick, J. Rust, eds. *Handbook of Computational Economics, Chapter 14*' (Elsevier-North Holland, Amsterdam, 1996, edn.), pp.
- [43] Hall, G., and Rust, J.: 'The (S, s) rule is an optimal trading strategy in a class of commodity price speculation problems', 2000
- [44] Traub, J.F., and Werschulz, A.G.: 'Complexity and information' (Cambridge University Press, 1998. 1998)
- [45] Felzenszwalb, P.F., and Zabih, R.: 'Dynamic programming and graph algorithms in computer vision', *IEEE transactions on pattern analysis and machine intelligence*, 2010, 33, (4), pp. 721-740
- [46] Esogbue, A.O.: 'Optimal clustering of fuzzy data via fuzzy dynamic programming', *Fuzzy Sets and Systems*, 1986, 18, (3), pp. 283-298
- [47] 'Highlight the Features of AWS, GCP and Microsoft Azure that Have an Impact when Choosing a Cloud Service Provider', *IJRTE*, vol. 8, no. 5, pp. 4124-4232, Jan. 2020, doi: 10.35940/ijrte.D8573.018520.
- [48] M. A. Kamal, M. K. Kamal, M. Alam, and M. M. Su'ud, 'Context-Aware Perspective Analysis working of RFID Anti-Collision Protocols', *jisr-c*, vol. 2, no. 16, Dec. 2018, doi: 10.31645/jisrc(2018).16.2.02.

- [49] M. A. Kamal, H. W. Raza, M. M. Alam, M. M. Su'ud, and A. binti A. B. Sajak, 'Resource Allocation Schemes for 5G Network: A Systematic Review', *Sensors*, vol. 21, no. 19, p. 6588, Oct. 2021, doi: 10.3390/s21196588.
- [50] M. A. Kamal, M. M. Alam, H. Khawar, and M. S. Mazliham, 'Play and Learn Case Study on Learning Abilities Through Effective Computing in Games', in *2019 13th International Conference on Mathematics, Actuarial Science, Computer Science and Statistics (MACS)*, Karachi, Pakistan, Dec. 2019, pp. 1–6. doi: 10.1109/MACS48846.2019.9024771.